

OEM

N0150.12
TRANSLATION OF ORIGINAL OPERATING AND
INSTALLATION INSTRUCTION
ENGLISH

DIAPHRAGM PUMP

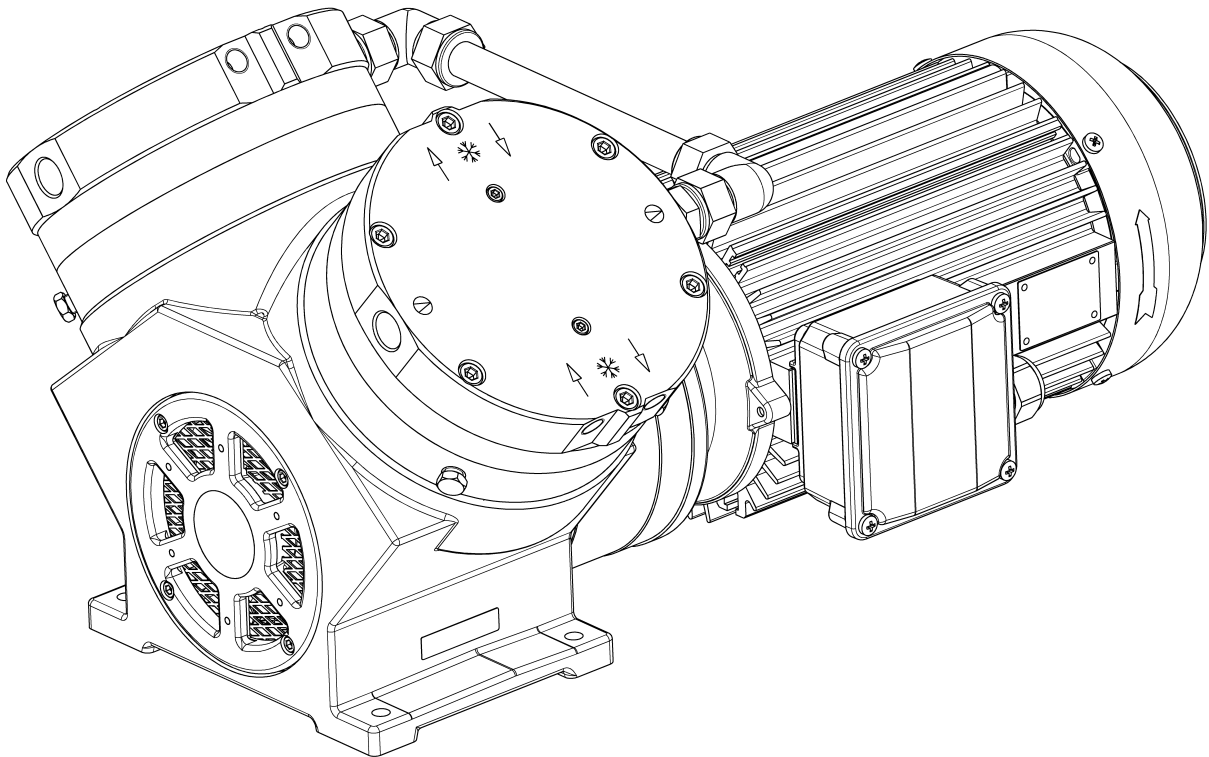

Notice!

Before operating the pump and accessories, read and observe the operating and installation instructions as well as the safety information!

KNF Neuberger GmbH
Alter Weg 3
79112 Freiburg
Germany
Tel. +49 (0)7664/5909-0
Fax. +49 (0)7664/5909-99

www.knf.com

Index

1	About this document	3
1.1	Using the operating and installation instructions.....	3
1.2	Exclusion of liability.....	3
1.3	Symbols and markings.....	3
2	Safety	5
2.1	Personnel and target group	5
2.2	Responsibility of the operator	5
2.3	Working in a safety conscious manner	6
2.4	Operating conditions	6
2.5	Media	6
2.6	Use.....	7
2.7	Directives and standards	8
2.8	Customer service and repair.....	9
2.9	Disposal	9
3	Technical data.....	10
3.1	Technical data.....	10
4	Product description	14
5	Transport.....	17
	General	17
	Transport with carrying strap	18
6	Installation and connection.....	20
6.1	Installing the pump.....	20
6.2	Electrical connection	22
6.3	Pneumatic connection.....	23
6.4	Installing monitoring device and monitoring diaphragm innerspace	24
6.5	Connecting water cooling (optional).....	24
7	Operation	27
7.1	General	27
7.2	Information on switching the pump on and off	29
8	Servicing	30
8.1	Servicing schedule.....	30
8.2	Cleaning.....	30
8.3	Changing the working diaphragm, safety diaphragm and reed valves.....	31
9	Spare parts and accessories.....	37
9.1	Spare parts	37
9.2	Accessories.....	37
10	Troubleshooting	38
11	Returns.....	41
12	Appendix	42
12.1	Motor.....	42

1 About this document

1.1 Using the operating and installation instructions

The operating and installation instructions are part of the pump.

- In the event of uncertainties with regard to the content of the operating and installation instructions, please contact the manufacturer (contact data: see www.knf.com). Please have the type and serial number of the pump ready.
- The individual chapters of these operating and installation instructions make reference to the operating instructions of the motor manufacturer for capacitor and three-phase motors. They are appended to these operating and installation instructions.
- Read the operating and installation instructions before you commission the pump.
- Give the operating and installation instructions only completely and unchanged to the next owner.
- Keep the operating and installation instructions within reach at all times.

Project pumps For customer-specific project pumps (pump models that begin with "PJ" or "PM"), there may be deviations from these operating and installation instructions.

- For project pumps, also observe the agreed specifications.

Optional contents Project-specific options may be included in the operating and assembly instructions. These are marked with "Optional". It is also possible that project-specific deviations are not included in the operating and assembly instructions.

Motor The operating and installation instructions apply for the pump part.

- Also observe the operating instructions for the motor in the appendix.

1.2 Exclusion of liability

The manufacturer assumes no liability for damages and malfunctions resulting from failure to observe the operating and installation instructions.

The manufacturer assumes no liability for damages and malfunctions resulting from changes or modifications to the device and improper handling.

The manufacturer assumes no liability for damages and malfunctions resulting from impermissible spare parts and accessories.

1.3 Symbols and markings

Warning notice



A notice that warns you of danger is located here.

Possible consequences of a failure to observe the warning notice are specified here. The signal word, e.g., Warning, indicates the danger level.

- Measures for avoiding the danger and its consequences are specified here.

Danger levels

Signal word	Meaning	Consequences if not observed
DANGER	warns of immediate danger	Death or serious injury or serious damage will result.
WARNING	warns of possible danger	Death, serious injury or serious damage is possible.
CAUTION	warns of a possibly dangerous situation	Minor injury or damage is possible.
NOTICE	Warns of possible damage	Damage is possible.

Tab.1 Danger levels







Other notices and symbols

→ An activity to be carried out is specified here (a step).

1. The first step of an activity to be carried out is specified here. Other sequentially numbered steps follow.

i This symbol indicates important information.

Explanation of pictograms

Pictogram	Meaning
	General warning symbol
	Warning of hot surface
	Warning of electrical voltage
	Warning of poisonous substances
	Warning of hand injuries through crushing
	Observe the operating instructions
	General mandatory sign

Tab.2 Explanation of pictograms

2 Safety



Observe the safety notices in Chapters 6 *Installation and connection* and 7 *Operation*.

2.1 Personnel and target group

Personnel Make sure that only specially trained and instructed personnel work on the pumps. This applies, in particular, to mounting, connection and servicing work.

Make sure that the personnel have read and understood the operating instructions, particularly the chapter on safety.

Target group	Target group	Definition
	User	Employee
	Specialized personnel	Specialized personnel are personnel who - have relevant professional training in the field covered in the particular section of text; - have current knowledge of the field covered in the particular section of text.

Tab.3 Target group

Who-does-what matrix	Lifecycle phase	User	Specialized personnel
	Transport		X
	Mounting		X
	Connection		X
	Commissioning	X	X
	Operation	X	X
	Servicing		X
	Troubleshooting		X
	Disposal		X

Tab.4 Who-does-what matrix

2.2 Responsibility of the operator

The pumps are produced in accordance with the generally recognized rules of engineering, as well as the occupational health, safety and accident prevention regulations. Nevertheless, dangers can arise during their use that lead to injuries to the user or third parties or to damage to the pump or other property.

Only use the pumps in perfect technical condition, for their intended use, safely and with an awareness of the dangers and in observation of the operating and installation instructions.

The components that are to be connected to the pumps must be designed according to the pneumatic data of the pumps.

When connecting the pumps to the electrical power, observe the corresponding safety rules.

Make sure that no hazardous situation, physical harm or impairment of the pump can occur.

Operating parameters Only operate and install the pump under the operating parameters and operating conditions described in Chapters 2.4 *Operating conditions* and 3 *Technical data*.

2.3 Working in a safety conscious manner

Observe the regulations on accident prevention and safety during all work on the pumps and during operation.

Avoid contact with the pump heads and housing parts because the pump heats up during operation.

When working on the pump, make sure that the pump is disconnected from mains and without power.

When connecting the pump to the electrical mains, observe the corresponding safety rules.

Ensure that no hazards arise from gas flowing when gas connections are open, from the effects of noise or from hot, corrosive, dangerous and environmentally hazardous gases.

Make sure that an EMC-compliant installation of the pump is ensured at all times to prevent the occurrence of dangerous situations.

Double diaphragm system For pump models with a double diaphragm system, a second diaphragm is located below the working diaphragm. This safety diaphragm is under less strain during pump operation, i.e. it is under significantly less tension than the working diaphragm.

In the event of a defect to the working diaphragm, no gas can escape from the pump. The closed safety space between the two diaphragms can be monitored to immediately detect damage to the working diaphragm. In such a case, the pump must be brought to a standstill within 24 hours by the system owner and the working and safety diaphragm must be replaced.

2.4 Operating conditions

Only use the pump in perfect technical condition, for its intended purpose, safely and with an awareness of the dangers and in observation of the operating instructions.

Protect the compressors with a pressure relief device between the pressure side of the compressor and the first shut-off valve.

Only install and operate the pumps in accordance with the operating parameters and conditions described in Chapter 3 *Technical data*.

Only pumps that are fully assembled and in the condition as delivered may be operated.

Make sure that the installation location is dry and that the pump is protected from rain, splash water, gushing water, dripping water and other contamination.

Check the tightness of the connections between the pipes of the application and the pump (or the connection of the pump) at regular intervals. Leaky connections carry the risk of releasing dangerous gases and vapors from the pump system.

2.5 Media

Requirements of pumped media Before transferring a medium, check whether the medium can be transferred without risk in the specific application.

Take note of any change in the state of matter (condensation, crystallization).

Before using a medium, check the compatibility of the media-contacting components (see 3 *Technical data*) with the medium.

Only transfer gases that remain stable under the pressures and temperatures that arise in the pump.

- Handling of hazardous media Upon breakage of the working diaphragm and/or leaks, the transferred medium will mix with the air in the inner space between the working diaphragm and the safety diaphragm and/or with the air in the surroundings.
- Risk of dangerous gas mixtures during pump operation if the working diaphragm breaks: Depending on the medium being transferred, breakage of the working diaphragm can result in a dangerous mixture if the medium mixes with the air in the innerspace between the working diaphragm and the safety diaphragm:
- KNF recommends monitoring the innerspace between the working diaphragm and the safety diaphragm (see item 5 in Fig. 5) through the hole(s) in the intermediate ring for a change in pressure. If the pressure changes in the innerspace, the pump is to be stopped immediately.
 - After breakage of the working diaphragm, the pump must be stopped immediately. Replace the working diaphragm and safety diaphragm prior to further operation (see Chapter 8 *Servicing*).
 - If pressure or flow rate changes without apparent reason, switch off the pump immediately and check the pump for damage.

Make sure that a dangerous situation cannot arise as a result.

When pumping hazardous media, observe the safety regulations for the handling of said media.

- Handling of combustible media Note that the pump is not designed to be explosion-proof.
- Make certain that the temperature of the medium is always sufficiently below the ignition temperature of the medium so as to prevent ignition or explosion. This also applies for abnormal operating situations.
- Note that the temperature of the medium increases when the pump compresses the medium.
- Therefore, make certain that the temperature of the medium also remains sufficiently below the ignition temperature of the medium even when it is compressed to the maximum permissible operating pressure of the pump. The maximum permissible operating pressure of the pump is stated in Chapter 3 *Technical data*.
- Make certain that the permissible ambient temperature (see 3 *Technical data*) is not exceeded.
- Where applicable, also take into account external energy sources (such as radiated heat sources) that could additionally heat the medium.
- In case of doubt, contact KNF Customer Service.

2.6 Use

2.6.1 Proper use

The pumps are intended exclusively for transferring gases and vapors.

The pumps are intended exclusively for operation in indoor areas and in non-explosive atmospheres.

2.6.2 Foreseeable misuse

The pumps must not be operated in explosive atmospheres.

The pumps are not suitable for transferring the following:

- Dusts
- Liquids
- Aerosols
- Biological and microbiological substances

- Fuels
- Explosives and flammable materials
- Fibers
- Oxidizing agents
- Foodstuffs.

As standard, the pumps must not be used for simultaneous generation of a vacuum and positive pressure.

This function can be made possible on a project basis following consultation with KNF Customer Service.

Do not apply positive pressure to the inlet of the pump.

This function can be made possible on a project basis following consultation with KNF Customer Service.

The pumps are not intended for operation with a frequency converter.

2.7 Directives and standards

EU/EC Directives	<p>Installation declaration – for partly completed machinery</p> <p>With respect to the Machinery Directive 2006/42/EC, the pumps are partly completed machinery and are, therefore, to be regarded as not ready for use. Partly completed machinery may not be commissioned until it has been determined that the machine into which the partly completed machinery is to be installed complies with the provisions of the Machinery Directive 2006/42/EC. The following fundamental requirements of Annex I of Directive 2006/42/EC (general principles) are applied and observed:</p> <ul style="list-style-type: none"> ▪ General principles no. 1 ▪ No. 1.1.2. / 1.1.3. / 1.3.1. / 1.3.3. / 1.3.4. / 1.4.1. / 1.5.1. / 1.5.2. / 1.5.8. / 1.5.9. / 1.7.4. / 1.7.4.1. / 1.7.4.3.
Standards	<p>The following standards apply:</p> <ul style="list-style-type: none"> ▪ EN 61000-6-1/2/3/4 ▪ EN 60034-1 ▪ EN 60034-30-1 (only pumps with three-phase motor) ▪ EN 60204-1 ▪ EN IEC 63000 <p>The protective goals of the following directive(s) are achieved:</p> <ul style="list-style-type: none"> ▪ Directive 2011/65/EU on the restriction of the use of certain hazardous substances in electrical and electronic equipment (Annex II changed by delegated Directive (EU) 2015/863 of the Commission) ▪ Directive 2014/35/EU on the harmonization of the laws of the Member States relating to the provision of electrical equipment for use within certain voltage limits on the market

2.8 Customer service and repair

- Customer service and repairs The pump is maintenance-free. However, KNF recommends periodic inspection of the pump for obvious changes in noise or vibration.
- Only have repairs to the pumps performed by qualified KNF personnel.
- Housings with electrically live components may only be opened by specialist personnel.
- Use only genuine spare parts from KNF when performing servicing work.

2.9 Disposal

- Environmental protection Store the pump and all accessories in accordance with the environmental provisions. Observe national and international regulations. This applies in particular to parts that are contaminated with toxic substances.
- If you no longer need your packaging materials (e.g. for return shipment or other transport of the device), dispose of them in an environmentally friendly manner.
- Old devices must not be disposed of with household waste. Proper disposal and recycling helps to protect natural resources and the environment. The end user is responsible for disposing of old devices according to national and international regulations. Alternatively, KNF products (old devices) may also be returned to KNF for a fee (see chapter *11 Returns*).

3 Technical data

3.1 Technical data

Pump materials

N0150SP.12E

N0150.3SP.12E

Assembly	Material
Head plate, intermediate plate, intermediate ring	Stainless steel
Working diaphragm	EPDM
Safety diaphragm	EPDM
Valve springs/valve limiter	Stainless steel
Retainer plate	Stainless steel
Conrod plate	Aluminum
O-rings	EPDM
Connection	Stainless steel

Tab.5

Pneumatic values

Parameter	Value	Value
	N0150SP.12E	N0150.3SP.12E
Max. permissible operating pressure [bar rel*]	1.0	0.5
-Continuous operation		
Ultimate vacuum [mbar abs.]	120	25
Flow rate at atm. pressure [l/min]**	130 ± 10%	130 ± 10%

Tab.6 *Bar rel related to 1013 hPa

**Liters in the standard state based on ISO 8778 and ISO 21360-1/2 (1013 hPa, 20°C)

Pneumatic connections

Pump type	Value
N0150.12	Thread size G 1/4*
N0150.3.12	Thread size G 1/4*
Hole for pressure monitoring of the inner space between the working diaphragm and safety diaphragm (see 6.4 Installing monitoring device and monitoring diaphragm innerspace)	Thread size G 1/8*

Tab.7 *Acc. to ISO 228

Connection for water cooling

Pump type	Value
N0150.12	Thread size G 1/4*
N0150.3.12	Thread size G 1/4*

Tab.8 *Acc. to ISO 228

Electrical data for pumps with capacitor motor**N0150.12**

Parameter	Value	Value	Value	Value
Voltage [V]*	100	115	220	230
Frequency [Hz]*	50/60	60	60	50
Power P ₁ [W]	**	**	**	900
Current draw [A]	**	**	**	7.8
Motor protection class (DIN EN 60529 / IEC 60529)	See motor type plate			
Max. permissible line voltage fluctuations	See operating instructions for motor			

Tab.9 *For further voltage and frequency variants, see type plate

**See type plate

N0150.3.12

Parameter	Value	Value	Value	Value
Voltage [V]*	100	115	220	230
Frequency [Hz]*	50/60	60	60	50
Power P ₁ [W]	1200	1000	**	1000
Current draw [A]	5	8.5	**	9.3
Motor protection class (DIN EN 60529 / IEC 60529)	See motor type plate			
Max. permissible line voltage fluctuations	See operating instructions for motor			

Tab.10 *For further voltage and frequency variants, see type plate

**See type plate

Electrical data for pumps with three-phase motor**N0150.12**

Parameter	Value	Value	Value	Value
Voltage [V]*	200/346	277/480	220/380	230/400
Frequency [Hz]*	50/60	60	60	50
Power P ₁ [W]	**	**	**	900
Current draw [A]	**	**	**	6.1/3.5
Motor protection class (DIN EN 60529 / IEC 60529)	See motor type plate			
Max. permissible line voltage fluctuations	See operating instructions for motor			

Tab.11 *For further voltage and frequency variants, see type plate

**See type plate

N0150.3.12

Parameter	Value	Value	Value	Value
Voltage [V]*	200/346	277/480	220/380	230/400
Frequency [Hz]*	50/60	60	60	50
Power P ₁ [W]	**	**	**	900
Current draw [A]	**	**	**	6.1/3.5
Motor protection class (DIN EN 60529 / IEC 60529)	See motor type plate			
Max. permissible line voltage fluctuations	See operating instructions for motor			

Tab.12 *For further voltage and frequency variants, see type plate

**See type plate

Weight

Pump type	Weight [kg] Three-phase motor	Weight [kg] Capacitor motor
N0150.12	Approx. 43	Approx. 48.5
N0150.3.12	Approx. 58.5	Approx. 63.5

Tab.13

Other parameters

Parameter	Value
Permissible ambient temperature [°C]	+ 5 to + 40
Permissible media temperature [°C]	+ 5 to + 40
Max. surface temperature* [°C]	+ 85
Dimensions N0150.12 N0150.3.12	See Chapter 6.1 <i>Installing the pump</i> Fig. 8 Fig. 9
Gas tightness** of the pump head (Leak rate): N0150SP.12E/N0150.3SP.12E	< 6 x 10 ⁻⁶ mbar l/s***
Highest permissible relative air humidity of the environment	80% for temperatures up to 31°C, decreasing linearly to 50% at 40°C.
Maximum installation altitude [m above sea level]	See operating instructions for motor
Pump protection class (DIN EN 60529 / IEC 60529) N0150.12 N0150.3.12	IP 20 IP 20
Noise**** [dB (A)]	Max. 70-80

Tab.14 *To reduce the surface temperature of the pump heads and to extend the service life of the diaphragm, you can optionally attach a water cooling system (see Chapter 6.5 *Connecting water cooling (optional)*).

**The gas tightness of the pump head is no longer ensured after the pump head is opened or after the diaphragm and valve springs are changed. A leak test can be used to determine whether the original gas tightness has been re-established.

***Values apply to helium leak test

****Max. emission sound pressure level over the entire pressure range with gas connections attached

Additional equipment

The pump is equipped with a safety diaphragm.

- For explanation of the task and principle, see Chapter 4 *Product description*.
- For information on installation and connection, see Chapter 6 *Installation and connection*.
- For information on operation, see Chapter 7.1 *General*.

4 Product description

Design

- 1 Pneumatic pump outlet
- 2 Pneumatic pump inlet
- 3 Electrical terminal box
- 4 Motor
- 5 Motor fan cover
- 6 Screw plug of the hole for pressure monitoring of the diaphragm innerspace (2x)
- 7 Connection for water cooling

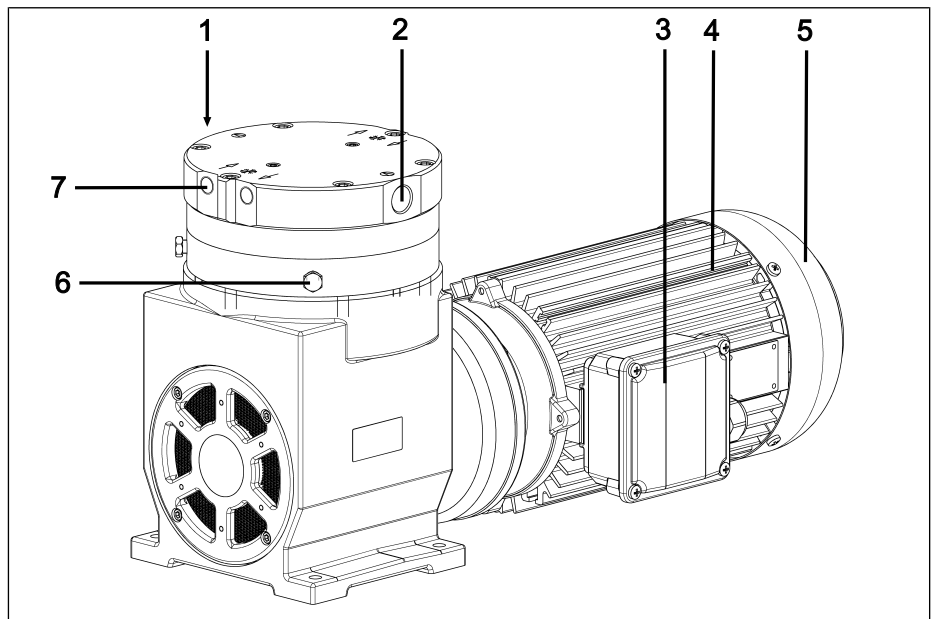

Fig.1 Diaphragm pump N0150.12 (three-phase motor)

- 1 Pneumatic pump outlet
- 2 Pneumatic pump inlet
- 3 Electrical terminal box
- 4 Motor
- 5 Motor fan cover
- 6 Screw plug of the hole for pressure monitoring of the diaphragm innerspace (2x)
- 7 Connection for water cooling

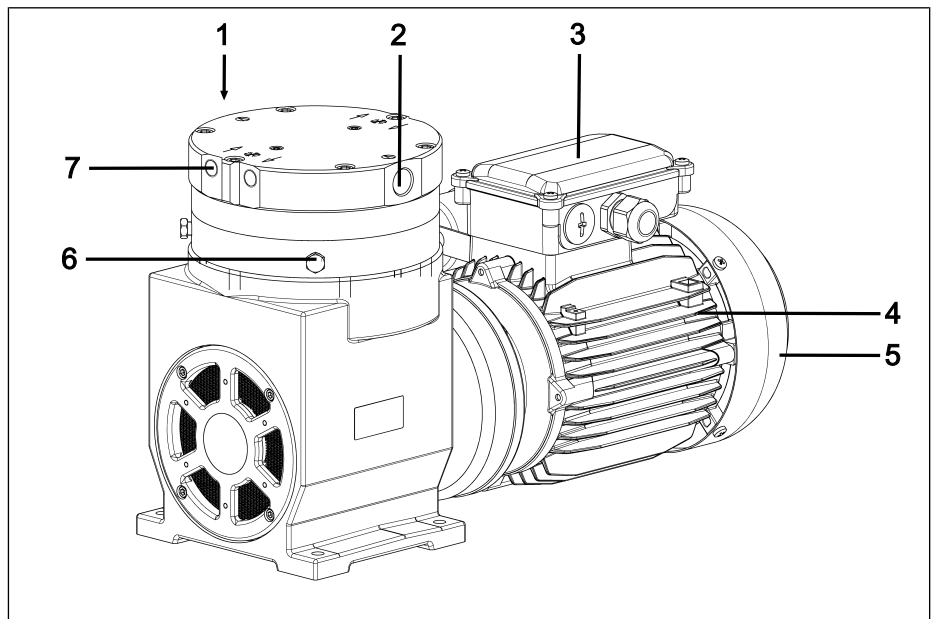

Fig.2 Diaphragm pump N0150.12 (capacitor motor)

- 1 Union nut
- 2 Connection for water cooling
- 3 Pneumatic head connection
- 4 Pneumatic pump inlet
- 5 Motor
- 6 Motor fan cover
- 7 Electrical terminal box
- 8 Screw plug of the hole for pressure monitoring of the diaphragm innerspace (2x per head)
- 9 Pneumatic pump outlet

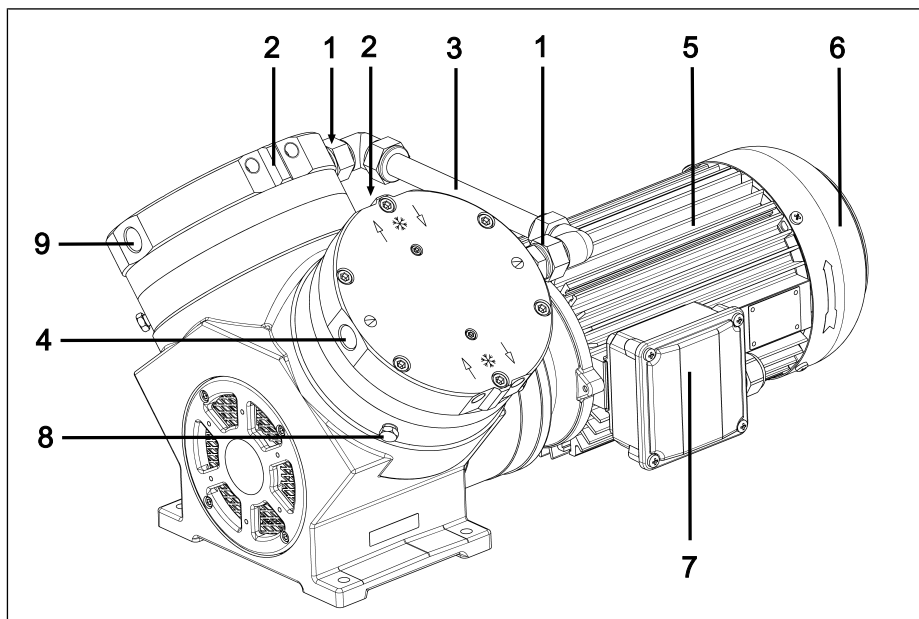

Fig.3 Diaphragm pump N0150.3.12 (three-phase motor)

- 1 Union nut
- 2 Connection for water cooling
- 3 Pneumatic head connection
- 4 Pneumatic pump inlet
- 5 Motor
- 6 Motor fan cover
- 7 Electrical terminal box
- 8 Screw plug of the hole for pressure monitoring of the diaphragm innerspace (2x per head)
- 9 Pneumatic pump outlet

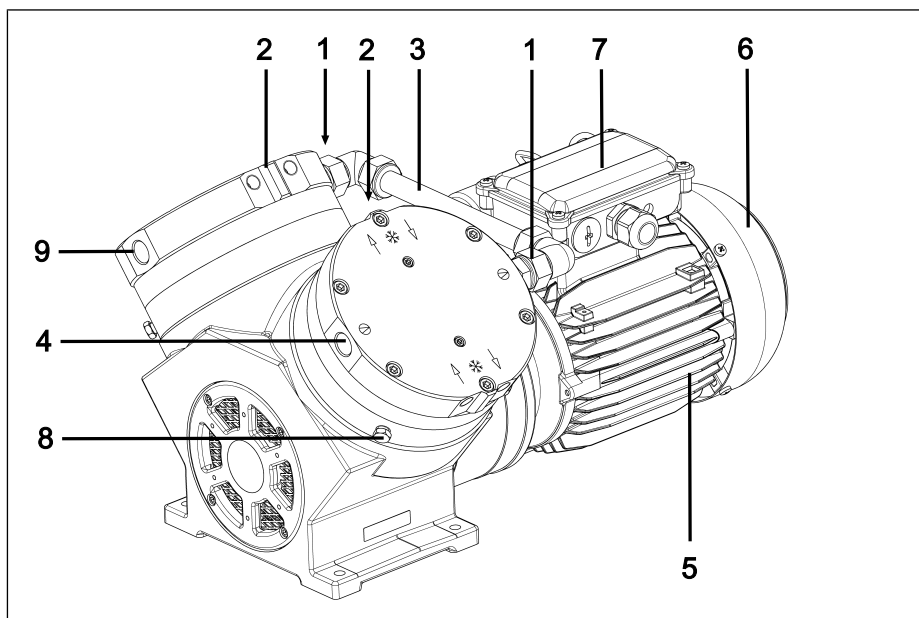

Fig.4 Diaphragm pump N0150.3.12 (capacitor motor)

Function of double diaphragm pump

- 1 Outlet valve
- 2 Inlet valve
- 3 Transfer chamber
- 4 Working diaphragm
- 5 Innerspace
- 6 Hole for pressure monitoring of the innerspace (5)
- 7 Safety diaphragm
- 8 Eccentric
- 9 Connecting rod

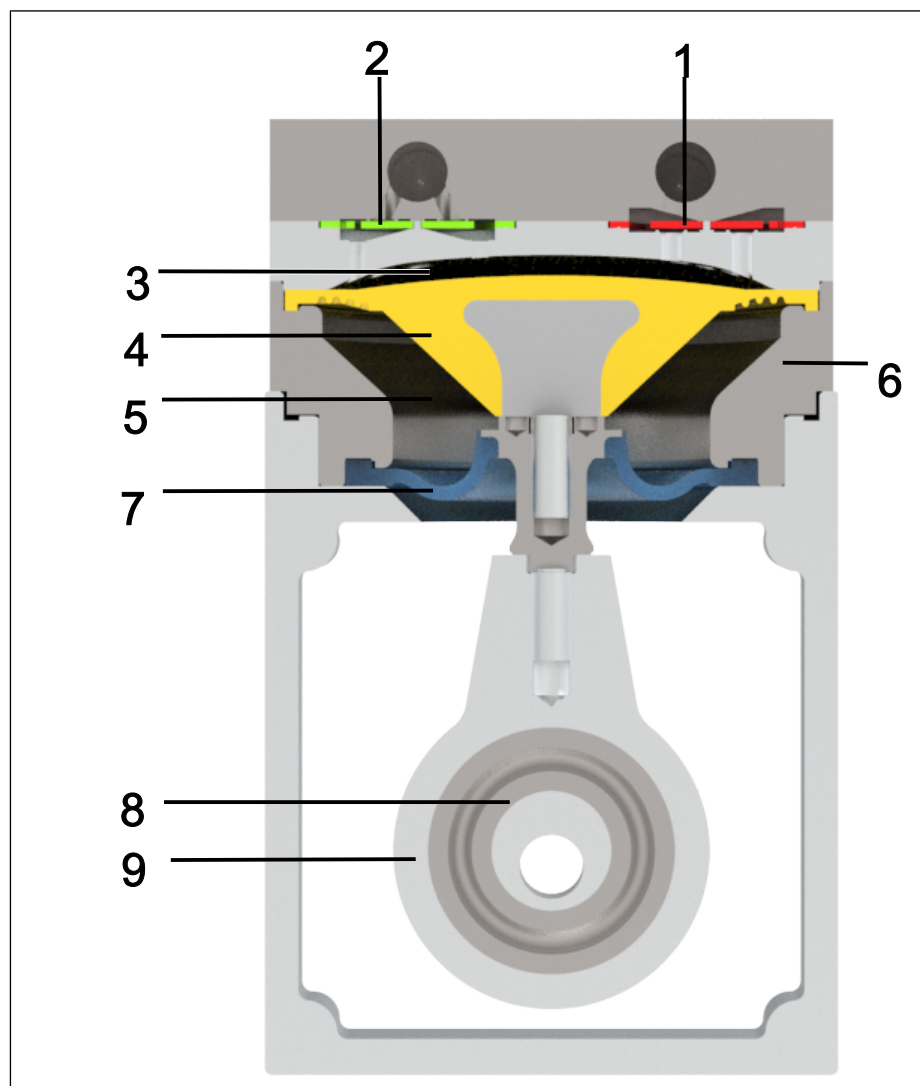

Fig.5 Function principle of double diaphragm pump

Double diaphragm pumps transfer, compress (depending on the version) and evacuate gases and vapors.

The elastic working diaphragm (4) is moved up and down by the eccentric (8) and the connecting rod (9). In the downwards stroke, it aspirates the gas to be transferred via the inlet valve (2). In the upwards stroke, the working diaphragm presses the medium out of the pump head via the outlet valve (1). The transfer chamber (3) is separated from the pump drive by the working diaphragm.

Located below the working diaphragm is a second diaphragm (safety diaphragm (7)), which is under less mechanical stress during pump operation. Should the working diaphragm be damaged, no gas can escape from the pump.

The closed innerspace (5) between the two diaphragms can be monitored for pressure change with the help of the hole(s) (6) provided for this purpose. Damage to the working diaphragm and safety diaphragm can thereby be detected immediately.

5 Transport

General



Personal injury and/or property damage due to incorrect or improper transport of the pump

In the event of incorrect or improper transport, the pump can fall down, be damaged or injure persons.

- Use suitable auxiliary means if necessary (carrying strap, lifting gear, etc.).
- Where appropriate, wear suitable personal protective equipment (e.g., safety shoes, safety gloves).



Risk of injury from sharp edges on the packaging

There is a risk of injury from cutting on the sharp edges when grabbing corners or when opening the packaging.

- Where appropriate, wear suitable personal protective equipment (e.g., safety shoes, safety gloves).

Only for two-headed pumps:



Personal injury and/or property damage due to incorrect or improper transport of the pump

If the pump is raised and/or carried on the connection during transport, leaks and/or damages to the pump may result.

- Do not carry the pump on the pneumatic connection.

- Transport the pump in the original packaging to the installation location.
- Keep the original packaging of the pump (e.g. for later storage).
- Inspect the pump for transport damage after receiving it.
- Document any transport damage that has occurred.
- Remove any transport safeguards on the pump prior to commissioning.

Parameter

Parameter	Value
Storage temperature [°C]	+ 5 to + 40
Transport temperature [°C]	- 10 to + 60
Permissible humidity (non-condensing) [%]	30 to 85
Max. storage period (Aging, ball-bearing grease) [Mon.]	48

Tab.15 Transport parameters and storage parameters



Prior to commissioning, make sure that the pump has reached the ambient temperature (*3 Technical data*).

Transport with carrying strap



Fig.6 Position of carrying strap (example)

1. Pull the carrying strap under the pump (see Fig. 6).



Fig.7 Fastening the carrying strap (pump shown as an example)

2. Fasten the carrying strap between compressor housing and motor (Fig. 1, see Fig. 7).
3. Make certain that the lifting load cannot be transferred from the belt to the pump connection.
4. Lift the pump from the packaging with the help of lifting gear.
5. Lower the pump carefully at the installation location.

6 Installation and connection

Only install the pumps in accordance with the operating parameters and conditions described in Chapter 3 *Technical data*.

→ Observe the safety instructions (see Chapter 2 *Safety*).



Risk of dangerous gas mixtures during pump operation

Depending on the medium being transferred, breakage of the media-contacting components can result in a dangerous mixture if the medium mixes with the air in the compressor housing or the surroundings.

→ Before using a medium, check the compatibility of the media-contacting components (see 3 *Technical data*) with the medium.

6.1 Installing the pump

→ Store the pump at the installation site to allow it to adapt to the ambient temperature before installation (condensation must not be allowed to form).

Mounting dimensions → For mounting dimensions, see the following illustrations:

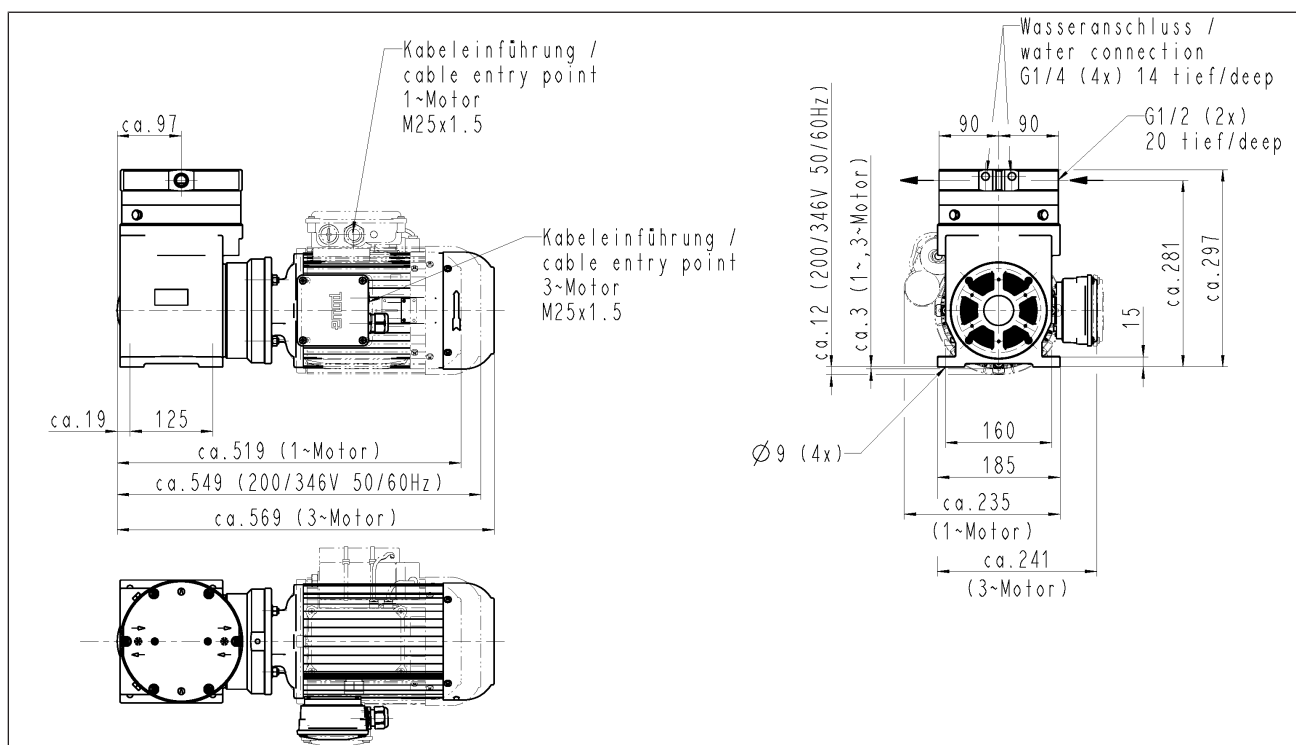

Fig.8 Mounting dimensions pump series N0150.12

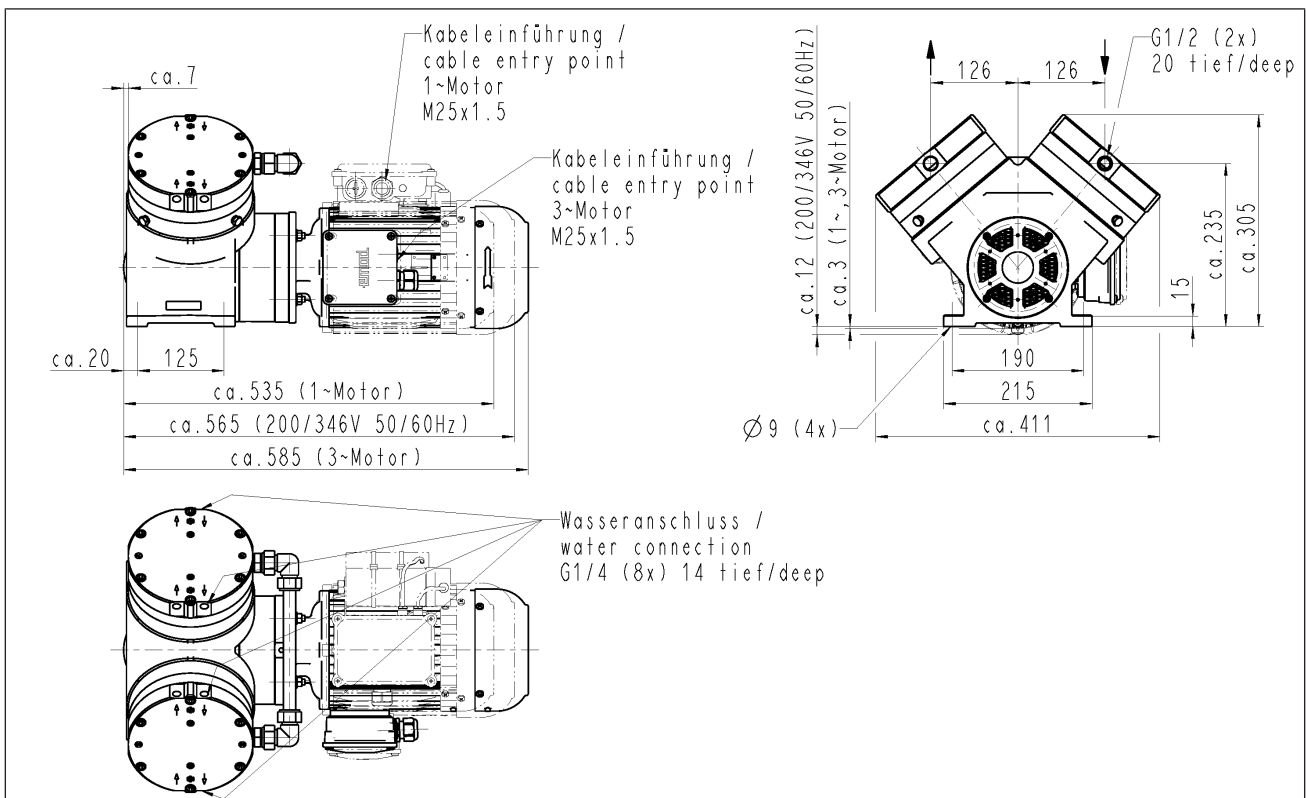

Fig.9 Mounting dimensions pump series N0150.3.12

Cooling air supply



Danger of burning on hot surfaces

Hot surfaces could occur if the pump overheats.

- When installing the pump, make sure that sufficient cooling air infeed and discharge is ensured.

Proximity to hot pump parts

- During installation, make sure that no combustible or thermally deformable objects are positioned in proximity to hot pump parts (head, motor).

Installation location

- Make sure that the installation location is dry and that the pump is protected from rain, spray water, splash water, dripping water and other contaminants.
- Make sure the installation location allows access for servicing.
- Make sure that the pump is securely attached to the intended fastening holes. If necessary, secure the pump to a base plate with rubber-bonded metal (see accessories, Chapter 9.2 *Accessories*; observe details on pump weight, Chapter 3 *Technical data*).
- Make sure that access to moving parts is prevented.

i The IP protection class of the pump motor is specified on the type plate.

- Install the pump at the highest point in the system to prevent condensate from collecting in the pump head.
- Protect the pump from dust.
- Protect the pump from vibration and impact.

Installation position



Personal injury and/or property damage from vibrations

Pump vibrations, in combination with adjacent components, can result in crushing and/or damage to these components.

- Make sure that pump vibrations cannot lead to dangers in combination with adjacent components.

Protection against foreign objects

- Protect the pump against contact and the ingress of foreign bodies.

6.2 Electrical connection



Danger to life from electric shock

- Only have the pump connected by an authorized specialist.

- Only have the pump connected if the power supply is disconnected.

- When connecting to a power source, observe the applicable standards, regulations, directives, and technical standards.

- When connecting to a power source, carefully read and observe the motor operating instructions (including the notice on insulation resistance measurement).



Automatic restart after interruption of the power supply

If the power supply is interrupted or the thermal overload fuse of the motor is activated, the pump will automatically restart.

- Take appropriate protective measures.

- Install a device for separating the pump motor from the electrical grid in the electrical installation (e.g. in accordance with EN 60335-1).



Refer to the type plate for the maximum current consumption of the pump.

- Install an Emergency Off device such that it is not possible for there to be an automatic restart or for hazardous situations to persons and property to occur.

- Install the pumps in such a way that it is not possible to touch electrically live parts (electrical connection).

Fastening the connection cables

- Fasten the connection cables so that
 - the cables do not come into contact with movable or hot parts.
 - the cables cannot be worn or damaged on sharp corners or edges
 - no tensile and pressure forces are exerted on the connection point of the cables (strain relief)

Connecting the pump

1. Confirm that the power supply meets the parameters listed on the pump type plate. Refer to the pump type plate for the rated current draw.
- i** For the permissible deviation of the supply voltage, see operating instructions for motor.
2. Open the terminal box cover.
3. Connect the ground conductor to the pump motor.
4. Connect the electrical power cables in accordance with the operating instructions for the motor.



NOTICE

Set the direction of rotation according to the arrow on the motor fan cowl (see 6.1 *Installing the pump* and the motor operating instructions).

5. Connect the thermal overload fuse (thermal switch, PTC thermistor sensor) (see operating and installation instructions for the motor).
6. Close the terminal box cover again.

6.3 Pneumatic connection



CAUTION

Personal injury or property damage through ejected plugs

If not removed, the plugs on the outlet of the pump can be ejected during operation by the resulting overpressure.

→ Remove the plugs during installation.

→ Wear appropriate personal protective equipment.

- Connected components → Only connect components to the pump that are designed for the pneumatic data and thermal requirements of the pump. (see Chapter 3 *Technical data*).
- Pressure relief device → Protect the compressors by means of a pressure relief device between the pressure-side connections of the compressor and the first shut-off valve.
- Pump discharge → Discharge the possibly hot pump discharge at the pneumatic outlet of the pump safely (with regard to medium and noise).
- Decoupling → KNF recommends mechanically decoupling the pump from the pipe system, e.g., through the use of flexible hoses or pipes. In this way it is possible to prevent the transfer of possible pump vibrations and noises to the system.

Connecting the pump

i A marking on the pump head indicates the flow direction.



Risk of injury due to mixing up inlet and outlet
 Mixing up the inlet and outlet may cause breakage of components connected at the inlet and outlet.

→ Observe the marking of inlet and outlet on the pump head.

1. Remove the protective plugs from the hose connection threads.
2. Connect the suction line and the pressure line (for mounting dimensions, see Chapter 3 *Technical data*).
3. Lay the suction line and pressure line with a descent so that no condensate can run into the pump.

i Pneumatic noises can be reduced or dissipated by using a silencer.

6.4 Installing monitoring device and monitoring diaphragm innerspace

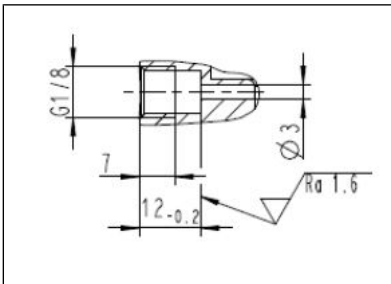

Fig. 10 Sectional drawing of hole for pressure monitoring



Risk of dangerous gas mixtures during pump operation if the working diaphragm breaks

Depending on the medium being transferred, breakage of the working diaphragm can result in a dangerous mixture if the medium mixes with the air in the innerspace between the working diaphragm and the safety diaphragm.

→ KNF recommends monitoring the innerspace between the working diaphragm and the safety diaphragm (see Fig. 5) through the hole(s) (see Fig. 10) in the intermediate ring for a change in pressure or the presence of gas. If the pressure changes in the innerspace, the pump is to be stopped immediately.

→ Immediately stop the pump if the working diaphragm breaks. Replace the working diaphragm and safety diaphragm prior to further operation (see Chapter 8 *Servicing*).

6.5 Connecting water cooling (optional)

i Water cooling (see 9.2 *Accessories*) can increase the service life of the diaphragm, particularly with high pressures or high ambient temperature.

Operating parameters

Parameter	Value
Water temperature [°C]	+ 5 to + 30
Water pressure [bar g]	< 1.0
Water flow rate [l/min]	> 1.0

Tab.16 Recommended parameters for connecting the water cooling

1. Connect the water cooling system to the provided hose connections.

→ Safely drain the water discharge.

i The flow direction is allowed in both directions.

Mounting dimensions For mounting dimensions, see the following dimensional drawings:

i The base plate is shown as an additional accessory on the following dimensional drawings.

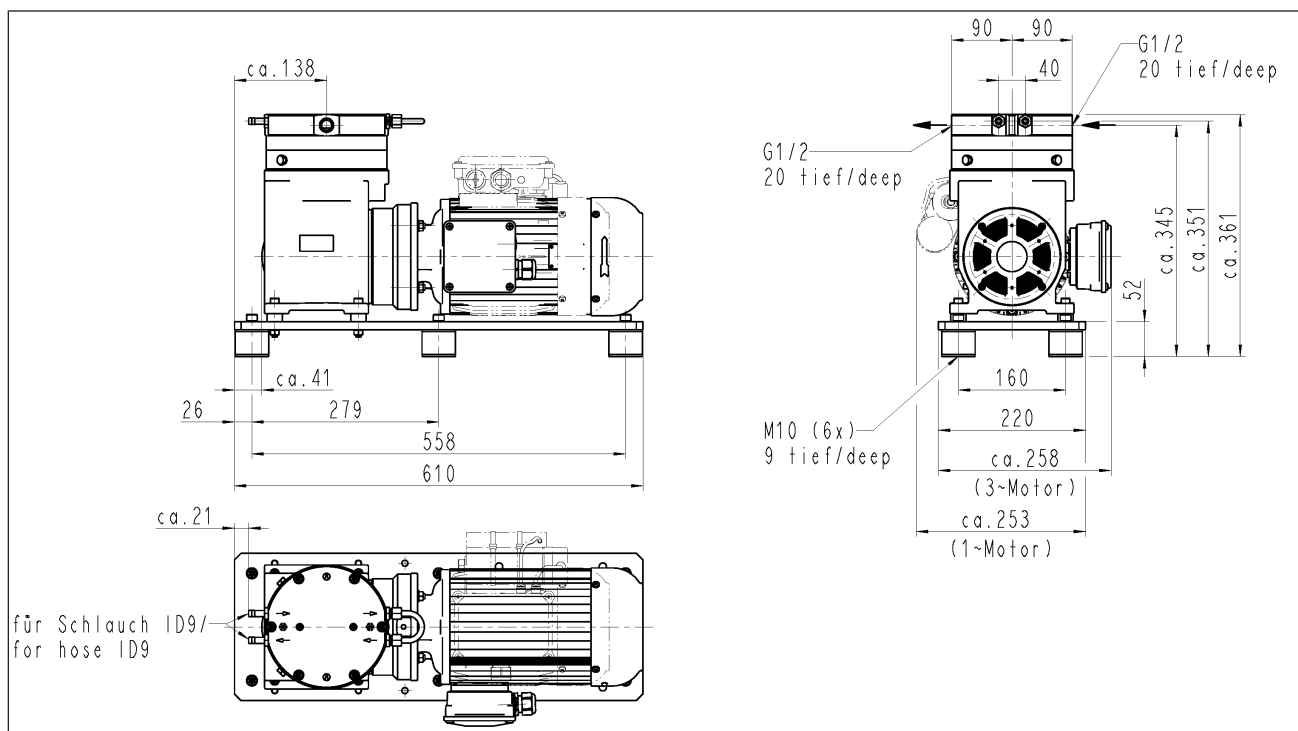

Fig.11 Mounting dimensions pump series N0150.12

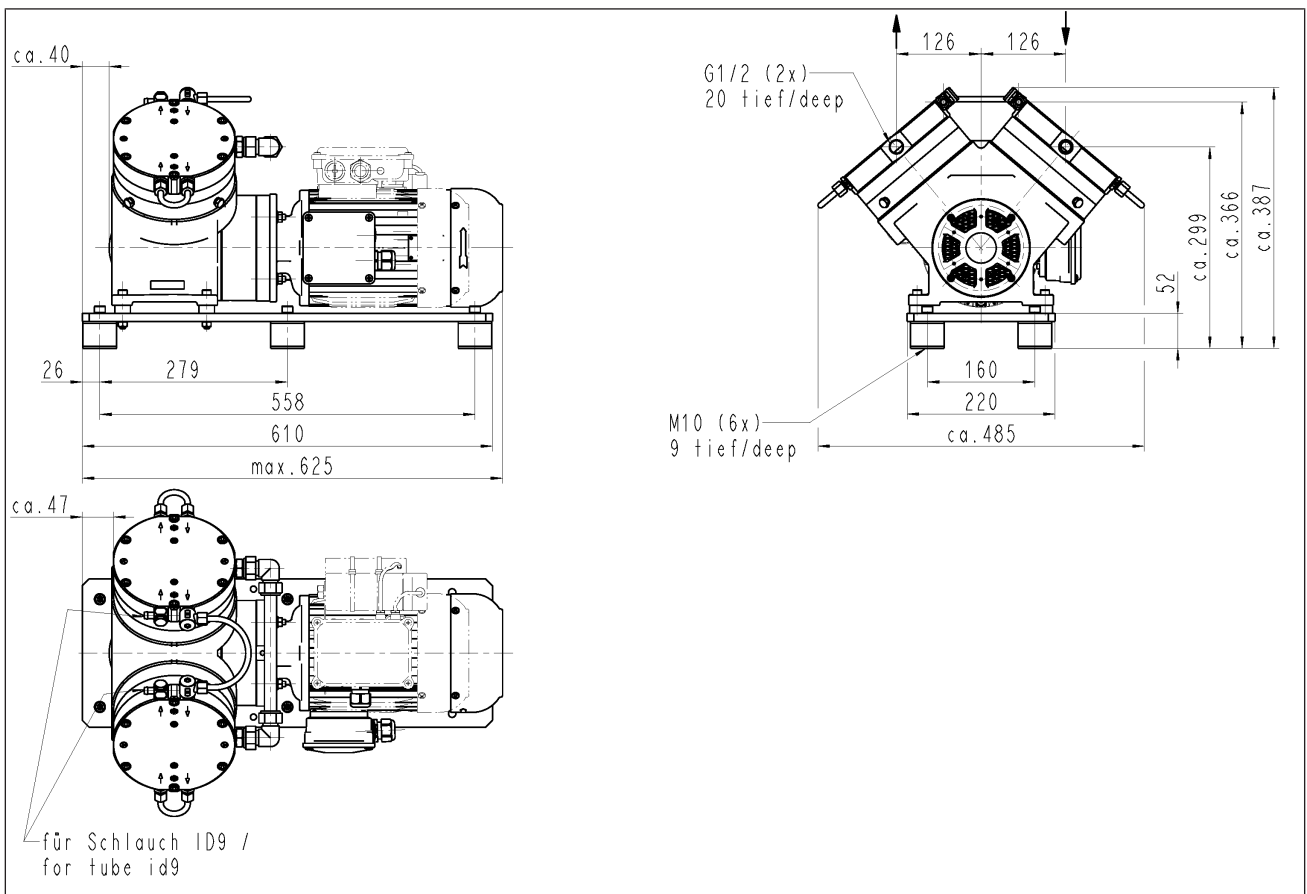

Fig.12 Mounting dimensions pump series N0150.3.12

7 Operation

7.1 General



Risk of burns from hot pump parts and/or hot medium

Some pump parts may be hot during or after operation of the pump.

- Allow the pump to cool after operation.
 - Take protective measures to protect against touching hot parts.
-



Damage to the pump due to overheating

If gases with a greater isentropic exponent than that of air (helium, argon, xenon, neon, krypton) are pumped, compressing these gases gives rise to higher gas temperatures. The higher temperatures may impair the functional capabilities of the parts of the pump that are in contact with the media and possibly also adjacent components (e.g., ball bearings). This in turn will shorten the service life of the pump.

- If necessary, contact KNF Customer Service.
-



Injury to eyes

Coming too close to the inlet/outlet of the pump may result in injury to the eyes due to the present vacuum/operating pressure.

- Do not look into the pump inlet/outlet during operation.
-

- Only operate the pumps under the operating parameters and operating conditions as described in Chapter 3 *Technical data*.
- Ensure the proper use of the pumps (See Chapter 2.6.1 *Proper use*).
- Rule out the possibility of foreseeable misuse of the pumps (see chapter 2.6.2 *Foreseeable misuse*).
- Observe the safety instructions (Chapter 2 *Safety*).
- The pumps are built-in devices. Before they are commissioned, it must be ensured that the machines or systems into which the pumps are installed comply with the relevant provisions.



Risk of bursting of pump head due to excessive pressure increase

- Do not exceed the maximum permissible operating pressure (see 3 *Technical data*).
- Monitor the pressure during operation.
- If the pressure exceeds the maximum permissible operating pressure of the pump: Switch the pump off immediately and remedy the malfunction (see Chapter 10 *Störung beheben*).
- Only throttle or regulate the air or gas quantity on the inlet line to prevent the maximum permissible operating pressure from being exceeded.
- If the air quantity or gas quantity on the outlet line is throttled or regulated, make sure that the maximum permissible operating pressure at the pump is not exceeded.
- Ensure that the pump outlet is not closed or restricted.



Excessive pressure, with all of the associated hazards, can be prevented by means of a bypass line with a pressure relief valve between the outlet and inlet of the pump. Further information is available from KNF Customer Service (contact data: see www.knf.com).



Risk of dangerous gas mixtures during pump operation if the working diaphragm breaks

If the working diaphragm should break, the medium will mix with the air in the innerspace between the working diaphragm and the safety diaphragm.

- Immediately stop the pump if the working diaphragm breaks. Breakage of the working diaphragm can be detected by monitoring the innerspace for a pressure change in the innerspace between the working diaphragm and the safety diaphragm. A change in the pressure or flow rate of the pump without apparent reason may also indicate breakage of the working diaphragm.
- Replace the working diaphragm and safety diaphragm prior to further operation (see Chapter 8 *Servicing*).

**NOTICE**

Operation with open gas connection at the inlet can result in contaminants and objects being drawn in.

-
- Pump standstill → When the pump is at a standstill, establish normal atmospheric pressure in the lines.
- Vapors as medium The service life of the diaphragm can be extended, if no condensate forms in the pump. Therefore:
- Perform any work with saturated or near-saturated vapors only with a warm pump.
 - KNF recommends: When pumping corrosive media, flush the pump before switching off (see Chapter 8.2.1 *Flushing the pump*) to extend the service life of the diaphragm.

7.2 Information on switching the pump on and off

Switching on the pump

i The pump must not be started up against pressure or vacuum during switch-on. This also applies during operation after a brief power failure. If a pump starts up against pressure or vacuum, the pump may block, thereby activating the thermal switch or triggering device for the PTC thermistor sensors and switching off the pump.

- Ensure that normal atmospheric pressure is present in the lines when switching on.

Switching off/decommissioning the pump

- Establish normal atmospheric pressure in the lines (relieve pump pneumatically).
- Recommissioning → Before recommissioning, observe the applicable standards, guidelines, regulations and technical standards at the electrical connection.
- Inspecting the pump → Inspect the pump periodically for external damage or leakage.

8 Servicing



NOTICE

Servicing the pump

Damage to the pumps can result from failure to observe the applicable legal regulations and procedures for the location or intervention by untrained or uninstructed personnel.

- Servicing may only be performed according to the legal regulations (e.g. work safety, environmental protection) and provisions.
- Servicing may only be performed by specialized personnel or trained and instructed personnel.

8.1 Servicing schedule

Component	Servicing interval
Pump	<ul style="list-style-type: none"> → Perform periodic inspections for external damage or leakage. → Periodically check for noticeable changes to noises and vibrations.
Gas connections	<ul style="list-style-type: none"> → Perform periodic inspections for external damage or leakage.
Working diaphragm, safety diaphragm and reed valves	<ul style="list-style-type: none"> → Replace if the pressure in the (monitored) innerspace between the working diaphragm and the safety diaphragm changes (working diaphragm is broken). → Replace if the pressure or flow rate of the pump changes for no apparent reason. → At the latest, replace when the pump flow rate decreases.
Motor mount	<ul style="list-style-type: none"> → See the operating and installation instructions for the motor; inquire with the manufacturer of the motor if necessary

Tab.17

8.2 Cleaning

8.2.1 Flushing the pump

When transferring dangerous and environmentally hazardous media, KNF recommends flushing the pump with air at atmospheric pressure for a few minutes prior to switch-off (if necessary for safety reasons: with an inert gas) to extend the service life of the diaphragm.

- Discharge the media safely.

8.2.2 Cleaning the pump

Requirements → Pump disconnected from mains and voltage-free



CAUTION

Risk of burns from hot pump parts

The pump head or motor may still be hot after operation of the pump.

→ Allow the pump to cool after operation.



WARNING

Health hazard due to dangerous substances in the pump

Depending on the medium being transferred, caustic burns or poisoning is possible.

→ Wear protective equipment if necessary, e.g., protective gloves, goggles.

→ Clean the pump with suitable measures.



NOTICE

During cleaning work, ensure that no fluids enter the interior of the housing.

→ Only clean the pump with a dry wiping cloth. When cleaning, use no solvents if possible as these can affect the plastic parts.

→ Only use solvents during cleaning if head materials are not corroded (ensure resistance of the material).

→ If compressed air is available, blow out the components.

8.3 Changing the working diaphragm, safety diaphragm and reed valves

Requirements → Disconnect the drive from the mains and ensure that it is deenergized.

→ Allow the pump and the drive to cool.

→ Clean the pump and free the pump of hazardous materials.

→ Remove the hoses/pipes from the pneumatic pump inlet and outlet.

Information on the procedure



WARNING

Risk of dangerous gas mixtures and leakage of the medium being transferred from the pump during pump operation if the safety diaphragm is not changed at the same time as the working diaphragm.

→ If the working diaphragm is changed, always change the safety diaphragm at the same time.



Health hazard due to dangerous substances in the pump

Depending on the medium being transferred, caustic burns or poisoning is possible.

- Wear protective equipment if necessary, e.g., protective gloves, goggles.
- Clean the pump with suitable measures.



Risk of burns from hot pump parts

The pump head or motor may still be hot after operation of the pump.

- Allow the pump to cool after operation.

i For two-headed pumps:
Servicing work should generally be performed on both heads at the same time.

- Always change the operating diaphragm and safety diaphragm together so as to maintain the flow rate and safety of the pump.

With multi-headed pumps, parts of the various pump heads might become mixed up.

- Change the parts of the individual pump heads that are to be replaced one at a time.

Spare parts	Spare part*	Item designation**	Quantity
	Operating diaphragm	(4)	1 (per pump head)
	Safety diaphragm	(8)	1 (per pump head)
	O-ring	(2)	2 (per pump head)
	O-ring	(9) and (18)	2 (per pump head)
	O-ring	(15) and (17)	2 (per pump head)
	Reed valve, suction side	(27)	2 (per pump head)
	Reed valve, pressure side	(23)	2 (per pump head)
	O-ring	(19)	2 (per pump head)
	Screw	(22) and (28)	4 (per pump head)

Tab.18 * According to spare parts list, Chapter 9.1 Spare parts

** According to Individual parts of the pump head

Tool and material

Quantity	Tool/material
1	4 mm hex driver with torque indicator
1	6 mm hex driver with torque indicator
1	Screwdriver blade width 5.5 mm
1	#2 Phillips screwdriver (for fan assembly)
1	Adjustable face spanner wrench for nuts with two holes, pin diameter 4 mm, length approx. 160 mm (available as wrench for retainer plate as KNF accessory, see Chapter 9.2 <i>Accessories</i>).
1	Felt-tip pen
1	Hot air gun
1	Adhesive (Loctite 2400) or similar product

Tab.19 *According to accessory list, Chapter 9.2 *Accessories*

- 1 Head plate
- 2 O-ring
- 3 Intermediate plate
- 4 Working diaphragm
- 5 Hexagon socket head cap screws
- 6 Intermediate ring
- 7 Housing
- 8 Safety diaphragm
- 9 O-ring
- 10 Shim ring(s)
- 11 Serrated washer
- 12 Hexagon socket head cap screws
- 13 Connecting rod
- 14 Conrod plate, bottom
- 15 O-ring
- 16 Conrod plate, top
- 17 O-ring
- 18 O-ring
- 19 O-ring
- 20 Retainer plate
- 21 Hexagon socket head cap screws
- 22 Slotted cheese head screw
- 23 Reed valve, pressure side
- 24 Valve stopper, pressure side
- 25 Screw plug
- 26 Hexagon socket head cap screws
- 27 Reed valve, suction side
- 28 Slotted cheese head screw
- 29 Valve stopper, suction side

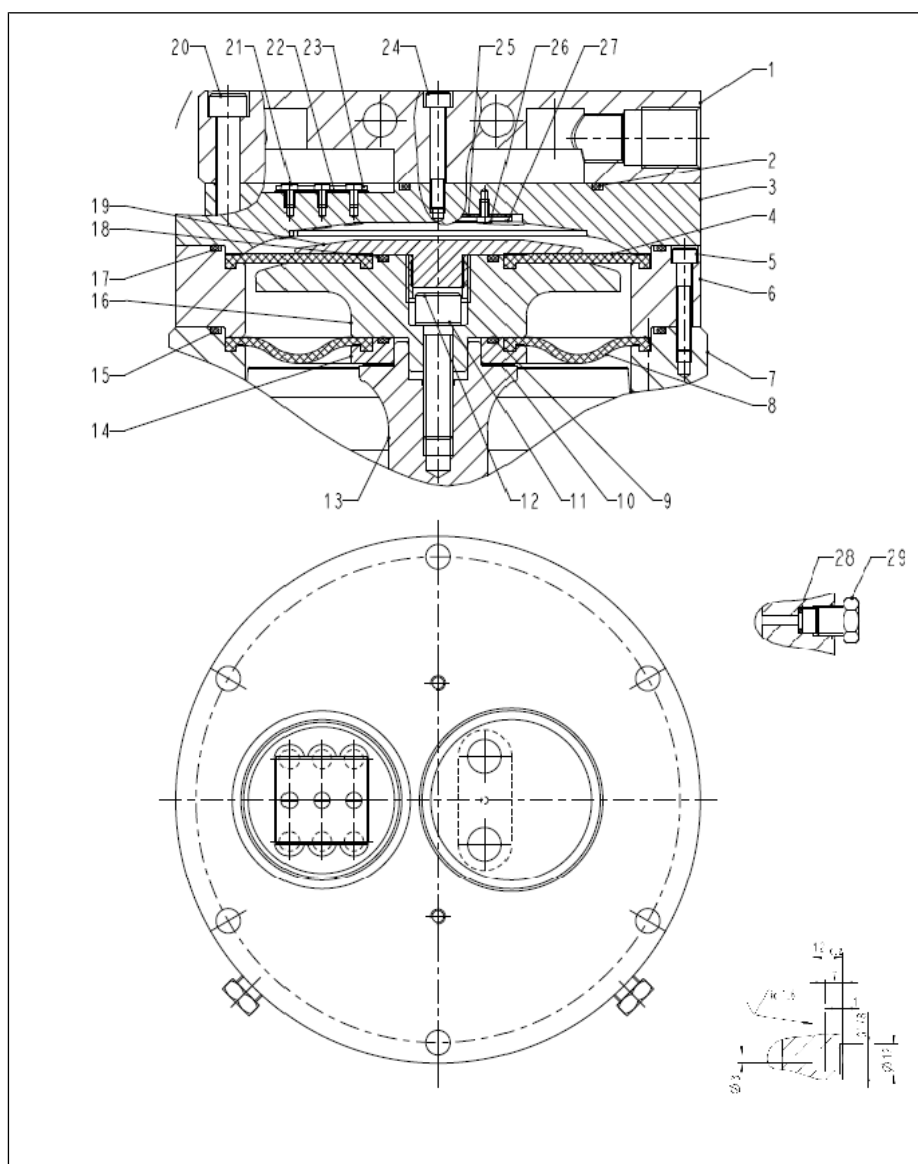

Fig.13 Individual parts of the pump head



The following item numbers refer to Individual parts of the pump head.

1. Accessing the fan blades:
Mark the motor fan cover with a continuous line made with a felt-tip pen (for later reassembly) and then loosen the fastening screws of the motor fan cover (see Chapter 4 *Product description*) and remove the cover.

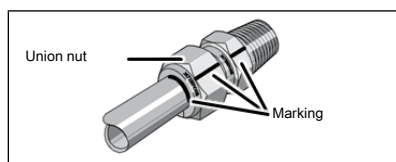

Fig. 14 Marking of the union nuts

2. For two-headed pumps only:
Remove the pneumatic connection between the pump heads; to do this, mark and loosen the union nuts according to Fig. 14.
3. Mark the head plate (1), intermediate plate (3), intermediate ring (6) and housing (7) with a continuous line made with a felt-tip pen. This helps to avoid incorrect assembly of the parts later.
4. Loosen the six hexagon socket head cap screws (21) as well as the two screws (26); Remove the head plate (1) and the intermediate plate (3).
5. Remove O-rings (2) and (17).
6. For two-headed pumps:
Perform steps 3 to 5 for the second pump head.

Changing operating diaphragm and safety diaphragm

1. Heat the retainer plate (20) with a hot-air gun ($T \approx 400^{\circ}\text{C}$) for approx. 5 minutes to approx. 100°C .



Risk of burns from hot parts

Burns may occur on skin contact with the hot retainer plate and countersunk screw or other heated pump parts.

- Wear protective gloves.
- Only loosen the retainer plate with face spanner wrench.
- Only place the retainer plate and countersunk screw on a heat-resistant surface.

2. Remove the retainer plate:
Loosen the retainer plate (20) from the conrod plate (16) with the wrench for retainer plate by turning counterclockwise and remove the retainer plate.
3. Remove the operating diaphragm (4).
4. Loosen the three hexagon socket head cap screws (5); remove the intermediate ring (6).
5. Loosen the hexagon socket head cap screw (12); remove the serrated washer (11) and the conrod plate (16).

i Caution: Take care not to let the shim ring(s) fall into the pump housing.

When removing the conrod plate, remove and set the shim ring(s) aside for safe keeping.

When remounting, use the exact same number of shim ring(s).

6. Remove the O-ring (15) from the housing (7).
7. Remove O-rings (13) and (9) from conrod plates (16) and (14).
8. Remove the safety diaphragm (8).
9. Check all parts for contamination and clean them if necessary.

i There may be glue residue on the external thread of the retainer plate as well as on the internal thread of the conrod plate. Remove this.

10. Insert the new O-ring (9) in the conrod plate (14).

11. Place the safety diaphragm (8) together with conrod plate (16) on conrod plate (14); make certain that the bulge on the inner diameter of the safety diaphragm (8) lies in the groove of the conrod plate (14).
12. Mount the conrod plate (16) with the serrated washer (11) and the hexagon socket head cap screws (12) (tightening torque: 45 Nm).
13. Insert the new O-ring (15) in the housing (7).
14. Place the intermediate ring (6) on the housing (7) according to the felt-tip pen marking and hand tighten the screws (5) crosswise; make certain that the bulge on the inner diameter of the safety diaphragm (8) lies in the groove of the housing.
15. Mount the hexagon socket head cap screws (5) (tightening torque: 9 Nm).
16. Insert the new O-ring (18) in the conrod plate (16).
17. Insert the new O-ring (17) in the intermediate ring (6).
18. Turn the fan blade to move the conrod plate (16) to the middle position.
19. Place the new operating diaphragm (4) on the conrod plate (16) and the intermediate ring (6); make certain that the bulge on the inner circumference of the operating diaphragm (4) lies in the groove on the conrod plate.
20. Apply the adhesive around the thread of the retainer plate (20) and in the threaded hole of the conrod plate (16) and screw the retainer plate into the conrod plate.
 - i** While screwing in, turn the retainer plate back one turn to allow the adhesive to spread onto both thread flanks (retainer plate and conrod plate).
 - i** Attention: Note the use-by-date for the adhesive.
The adhesive may lose its effectiveness after the use-by-date has passed.
21. Then securely tighten retainer plate (20) with the wrench for retainer plate (tightening torque: 20 Nm).
 - i** Attention: Observe the hardening time for the adhesive before recommissioning the pump.
The hardening time for the adhesive is approx. 24 hours.
22. For two-headed pumps:
Perform steps 1 to 21 for the second pump head.

Changing reed valves

1. Loosen the screws (22) and (28) and remove valve limiters (24) and (29) and reed valves (23) and (27) from the intermediate plate (3).
2. Mount the new reed valves together with the valve limiters on both the suction and pressure sides.
3. For two-headed pumps:
Perform steps 1 and 2 for the second pump head.

Fitting the pump head

1. Place the intermediate plate (3) on the intermediate ring (6) according to the felt-tip pen marking (diaphragm should be held in middle position by holding the fan blade).
2. Insert the two new O-rings (2) in the intermediate plate (3).
3. Place the head plate (1) on the intermediate plate (3) according to the felt-tip pen marking.
4. Screw in the hexagon socket head cap screws (2) and (26) one to two threads.

5. Tighten the two hexagon socket head cap screws (26) (tightening torque: 6 Nm), then tighten the hexagon socket head cap screws (21) crosswise (tightening torque: 9 Nm).
6. Check the pump for smooth running by turning the fan wheel.
7. For two-headed pumps:
Perform steps 1 to 6 for the second pump head.
8. Install the motor fan cover (see Chapter4 *Product description*) according to the felt-tip pen marking.
9. For two-headed pumps:
Remount the pneumatic connection between the pump heads. In doing so, retighten the union nuts to the original position (as marked during disassembly, see Fig. 14).

i When fitting the motor fan cover, make sure that all of the screws are fitted again, the fan cover and the fan are undamaged, and the fan can rotate freely. To do this, perform a function test.

10. Function test
Perform a function test.
 - Connect the suction and pressure sides to the pump.
 - Electrically connect the pump.
 - Test the functionality of the pump.
 - Disconnect the pump electrically and pneumatically again.
11. Pump integrated in application
 - Connect the suction and pressure sides to the pump.
 - Electrically connect the pump.
 - Test the functionality of the pump.

9 Spare parts and accessories

i To order spare parts and accessories, please contact your KNF sales partner or KNF Customer Service (contact data: see www.knf.com).

9.1 Spare parts

Spare part set

A spare part set consists of:

Parts	Item number*	Quantity N0150.12	Quantity N0150.3.12
Working diaphragm	(4)	1	2
Safety diaphragm	(8)	1	2
O-ring	(2)	2	4
O-ring	(9) and (18)	2	4
O-ring	(15) and (17)	2	4
Reed valve, suction side	(27)	1	2
Reed valve, pressure side	(23)	1	2
O-ring	(19)	2	4
Screw	(22) and (28)	4	8

Tab.20 *see Chapter 8.3 Changing the working diaphragm, safety diaphragm and reed valves

Spare part set	Order number
N0150SP.12E	315470
N0150.3SP.12E	315475

Tab.21

9.2 Accessories

Accessories	Order number
Water cooling connection: N0150S_.12	305998
N0150.3S_.12	306766
Suction filter G1/4	316662
Base plate with anti-vibration buffers: N0150.12 N0150.3.12	304463
Face spanner wrench	128753

Tab.22

10 Troubleshooting



Danger: electric shock can be life-threatening.

- All work on the pump may only be performed by an authorized specialist.
- Before working on the pump: Disconnect the pump from the power supply.
- Check and ensure that no voltage is present.

- Allow the pump to cool before troubleshooting.
- Check the pump (see following tables).

Pump not delivering	
Cause	Troubleshooting
Pump is not connected to the electrical mains.	→ Connect the pump to the electrical mains.
No voltage in the electrical mains.	→ Check the circuit breaker for the room and switch it on if necessary.
Pneumatic connections or lines are blocked.	→ Check the connections and lines. → Remove the blockage.
External valve is closed or filter clogged.	→ Check external valves and filters.
Condensation has collected in the pump head.	→ Separate the source of the condensation from the pump. → Flush the pump with air at atmospheric pressure for a few minutes (if necessary for safety reasons: with an inert gas). → Install the pump at the highest location in the system.
Working diaphragm, safety diaphragm or valves are worn or defective.	→ Replace the working diaphragm, safety diaphragm and valves (see Chapter 8 <i>Servicing</i>).

Tab.23

Flow rate, pressure or vacuum too low	
The pump does not reach the performance stated in the technical data or data sheet.	
Cause	Troubleshooting
Condensation has collected in the pump head.	<ul style="list-style-type: none"> → Separate the source of the condensation from the pump. → Flush the pump with air at atmospheric pressure for a few minutes (if necessary for safety reasons: with an inert gas). → Install the pump at the highest location in the system.
There is overpressure on the pressure side and at the same time vacuum or pressure above atmospheric pressure on the suction side.	<ul style="list-style-type: none"> → Change the pneumatic conditions.
Pneumatic lines or connection parts have insufficient cross-sections or are constricted.	<ul style="list-style-type: none"> → Disconnect the pump from the system to determine the output values. → Eliminate any constriction (e.g. valve). → Use lines or connection parts with a larger cross-section if necessary.
Leaks occur at pneumatic connections, lines or pump head.	<ul style="list-style-type: none"> → Eliminate the leaks.
Pneumatic connections or lines are partially or completely blocked.	<ul style="list-style-type: none"> → Check the pneumatic connections and lines. → Remove any parts or particles that are causing blockages.
Head parts are soiled.	<ul style="list-style-type: none"> → Clean the head components.
Operating diaphragm broken	<ul style="list-style-type: none"> → Stop the pump immediately. → Check whether the pressure has changed in the monitored innerspace between working diaphragm and safety diaphragm. Replace working diaphragm and safety diaphragm prior to further operation of the pump (see <i>8 Servicing</i>).
Working diaphragm, safety diaphragm or valves are worn or defective.	<ul style="list-style-type: none"> → Replace the working diaphragm, safety diaphragm and valves (see Chapter <i>8 Servicing</i>).

Tab.24

Pump exhibiting changed running noises and vibrations	
Cause	Troubleshooting
Pump bearing worn or defective.	<ul style="list-style-type: none"> → Determine the cause. → Contact KNF Customer Service.

Tab.25

Fault cannot be rectified

If you are unable to identify any of the specified causes, send the pump to KNF Customer Service (contact data: see www.knf.com).

1. Flush the pump with air for a few minutes (if necessary for safety reasons: with inert gas) at atmospheric pressure to free the pump head of dangerous or aggressive gases (see Chapter 8.2.1 *Flushing the pump*).
2. Clean the pump (see Chapter 8.2.2 *Cleaning the pump*).
3. Send the pump together with completed Health and Safety Clearance and Decontamination Form to KNF, specifying the pumped medium.

11 Returns

Preparing for return

1. Flush the pump with air for a few minutes (if necessary for safety reasons: with inert gas) at atmospheric pressure to free the pump head of dangerous or aggressive gases (see Chapter 8.2.1 *Flushing the pump*).

i Please contact your KNF sales partner if the pump cannot be flushed due to damage.

2. Remove the pump.
3. Clean the pump (see Chapter 8.2.2 *Cleaning the pump*).
4. Send the pump together with the completed Health and Safety Clearance and Decontamination Form to KNF, stating the nature of the transferred medium.
5. Pack the device securely to prevent further damage to the product. If necessary, request original packaging for a fee.

Returns

KNF shall undertake to repair the pump only under the condition that the customer presents a certificate regarding the medium that is pumped and the cleaning of the pump. In this case too, old devices can be returned. Please follow the instructions at [knf.com/repairs here](https://www.knf.com/repairs).

Contact your KNF sales partner directly if you require additional support for your return service.

12 Appendix

12.1 Motor

For further information, see also

- Betriebsanleitung Drehstrommotor.pdf
- CE-Erklärung Drehstrommotor.pdf
- Betriebsanleitung Kondensatormotor.pdf
- CE-Erklärung Kondensatormotor DE-EN.pdf

Operating manual for three-phase motors (IE2
+ IE3 in accordance with IEC 60034-30-1)
Frame size HEFIE2 / IE3 56L/.. - HEFIE2 / IE3 450L/..

Issue:2.0 - 07/21

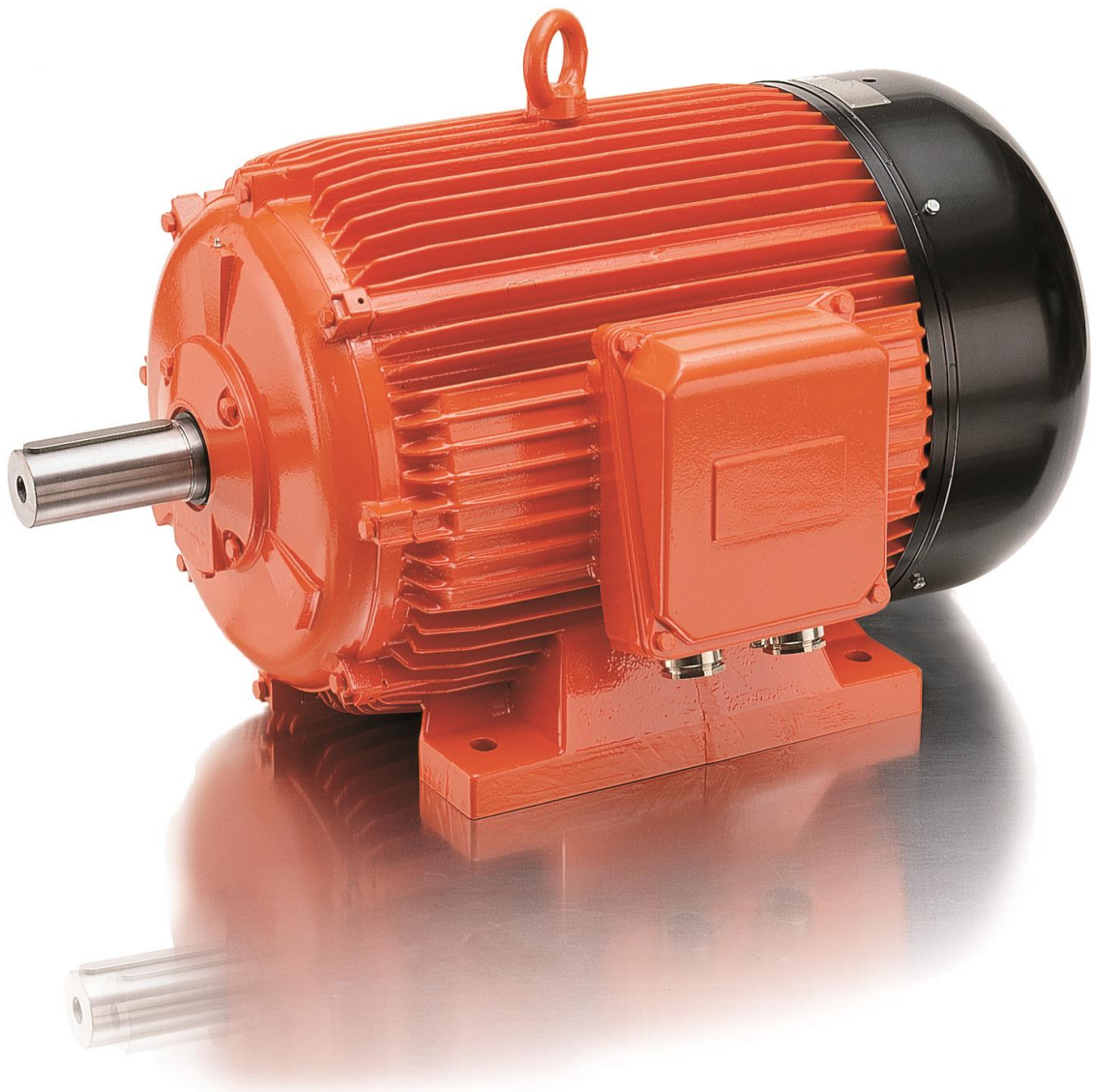

EMOD Motoren GmbH

Electric motor factory

Zur Kuppe 1

36364 Bad Salzschlirf

Germany

Phone: +49 6648 51-0

Fax: +49 6648 51-143

info@emod-motoren.de

www.emod-motoren.de

Table of contents

1	General information	4
1.1	Area of application	4
1.2	Explanation of the labels used	4
1.3	List of safety and installation notes	5
1.4	Limitation of liability	5
1.5	Safety	6
2	Transportation and storage	6
2.1	Transportation	6
2.2	Storage	6
3	Installation and commissioning	7
3.1	Positioning	7
3.1.1	Location	7
3.2	Mountings for motors	7
3.3	Condensation drain holes	7
3.4	Balancing	7
3.5	Insulation resistance check	7
3.6	Electrical connection	8
3.7	Motor protection	8
3.7.1	Thermistor	8
3.8	Commissioning	8
4	Maintenance	9
4.1	Inspection	9
4.2	Bearings	9
4.2.1	Bearings with permanent lubrication	9
4.2.2	Bearings with re-lubrication	9
4.3	Repair	10
4.3.1	Joint sealing	10
5	Spare parts	10
6	Final decommissioning (disassembly, recycling, disposal)	10
7	Appendix	11
8	Declaration of conformity	14
9	Documents provided	15









1 General information

Note	
	<p>The safety instructions contained in this operating manual must be observed!</p> <p>Special designs and structural variants may differ from the basic type in terms of technical details. If there are any uncertainties, we strongly advise you to contact EMOD Motoren GmbH. Always state the motor type and motor number.</p>

1.1 Area of application

The motors can be used in accordance with the protection class stamped on the rating plate, the type of construction intended by the manufacturer according to the catalogue or the customer's information. When using custom motors, the information in the quote and order confirmation also applies.

1.2 Explanation of the labels used

Symbol	Meaning
 Danger	Indicates an immediate danger to life and health. Results in death or serious injury if not prevented.
 Warning	Indicates a possible danger to life and health. May result in death or serious injury if not prevented
 Caution	Indicates a possible danger to life and health. May result in slight or minor injuries if not prevented.
Note	Indicates a potentially harmful situation. The system or things in the surrounding area may be damaged if not prevented.
	Warning of a danger (general). The type of danger is specified by the accompanying warning text.
	Warning of dangerous electrical voltage and its effect.
	Warning of hot surface.
	Warning of suspended load.
	Warning of explosive atmosphere.

1.3 List of safety and installation notes



Caution

Electric motors have dangerous, live and rotating parts. All work during connection, commissioning, maintenance and disposal may only be carried out by qualified professionals. (Observe EN 50110-1 and IEC 60364) Before beginning any work, any in particular before opening covers, the drive must be isolated according to regulations. In addition to the main circuit, any auxiliary circuits which may be present must be taken into account here.

Compliance with the 5 safety rules:

- Isolate
- Secure against being switched on again
- Establish the absence of voltage
- Earth and short-circuit
- Cover or block off adjacent live parts

The measures specified above may only be withdrawn after the work has been completed and the drive is fully installed. Improper conduct may result in injuries and property damage. The applicable national, local and system-specific provisions and requirements must be observed and complied with.



Warning

The proper and safe operation of the products assumes proper transportation, proper storage, positioning and installation, and careful operation and maintenance.



Caution

The surfaces of the motors may be ≥ 55 °C during operation! The hot surfaces should not be touched.



Note

Products with a weight of ≥ 20 kg should only be moved and lifted with appropriate lifting devices.

1.4 Limitation of liability

All information and instructions in this manual have been put together taking the applicable standards and regulations, the state of the art and our many years of knowledge and experience into account.

The manufacturer assumes no liability for damage resulting from:

- Failure to observe the manual
- Improper use
- Use of untrained personnel
- Unauthorised modifications
- Technical modifications
- Use of unapproved spare parts

The obligations agreed in the supply contract, the general terms and conditions, as well as the manufacturer's delivery conditions, and the applicable statutory provisions at the time of signing of the contract apply.

We reserve the right to make technical changes within the context of the performance characteristics and further development.

1.5 Safety

⚠ Warning	
	Installation, commissioning and maintenance may only be carried out by personnel with suitable training and qualifications.

In this respect, special attention should be paid to:

- the technical data and information concerning the proper use (commissioning, environmental and operational conditions), which are stated in the catalogue, the operation manual, the rating plates and the additional product documentation,
- the relevant construction and accident prevention regulations,
- the correct use of tools, lifting and transport devices,
- the implementation of protection measures against unintentional contact when installed to prevent endangerment of persons due to moving parts,
- the use of personal protective equipment.

2 Transportation and storage

⚠ Warning	
	<p>Danger due to heavy loads severe injuries and property damage possible</p> <ul style="list-style-type: none"> ▶ Products with a weight of ≥ 20 kg should only be moved and lifted with appropriate lifting devices ▶ Only use the intended lifting eyes for transportation of the fully assembled drive unit ▶ Do not lift the complete drive unit at the motor transport eyes

2.1 Transportation

The motors must be inspected for transport damage upon receipt. Any possible damage should be documented in detail in writing.

Motors with cylindrical roller bearings are protected against bearing damage by transport protection. The transport protection must be removed before raising of the transfer elements and commissioning.

2.2 Storage

The storage location should be as dry, clean, stable in temperature and free from vibrations as possible.

So that the lubrication film in the motor bearings and the sealing systems is not stripped off, the motor shaft should be turned a few times by hand, e.g. at monthly intervals, during long storage periods.

The motor rolling bearings should be re-greased or replaced if the period between delivery and commissioning is more than 4 years. In unfavourable storage conditions, this period is significantly reduced.

3 Installation and commissioning

⚠ Danger	
	<p>Installations and work may only be carried out with the device deenergised (separated from the mains) and the motor shut down.</p> <p>Death, cardiac arrhythmia</p> <p>► Observe the 5 safety rules, see chapter List of safety and installation notes on page 5</p>

3.1 Positioning

3.1.1 Location

The motors should be installed/fitted while easily accessible and at an ambient or coolant temperature +60°C. Altitude of site max. 1000 m (above sea level).

The cooling air should be able to flow in and out unhindered and should not be directly sucked in again. The air inlets and outlets, as well as the channels between the cooling ribs, should be protected against dust and dirt and regularly cleaned.

If the product is installed with the shaft end upwards or downwards, it should be guaranteed that no water can penetrate the upper bearing.

3.2 Mountings for motors

Foot-mounting motors must be positioned and mounted on an even, vibration-free surface. All mounting feet must lie flat; place thin sheets underneath for levelling if necessary.

For flange motors, care must be taken to ensure the axial run-out of the counterflange. Axial run-out errors may result in bearing damage and/or the failure of sealing systems.

3.3 Condensation drain holes

Care must be taken to ensure that the available condensation drain holes are located at the lowest point of the motor after installation and are kept free from dirt.

Closed condensation drain holes (if present) should be opened from time to time and closed again before each start-up.

3.4 Balancing

⚠ Danger	
	<p>Rotating parts</p> <p>Severe injuries</p> <p>► Secure feather keys against being ejected</p>

The balancing type is indicated on the shaft end face of the motor shafts in accordance with DIN ISO 8821:

- Balancing with a half key "H"
- Balancing with a full key "F"

Observe the appropriate balancing type when installing the drive element!

3.5 Insulation resistance check

Before commissioning of the motor, or after a longer storage period or downtime (more than 6 months), the insulation resistance of the winding should be checked. Check the winding against mass by means of an insulation resistance measuring device (max. DC voltage 500 V). If the minimum

insulation resistance at a winding temperature of 25 °C is smaller than 30 MΩ, or smaller than 1 MΩ at a winding temperature of 75 °C, the motor winding should be dried until the required minimum insulation resistance is reached. The winding temperature should not exceed 80 °C in this regard! Loosen the bearing plate, so that an air exchange can be carried out with closed motors. After the winding has been dried out, the bearing needs to be serviced (see corresponding chapter!).

3.6 Electrical connection

The mains voltage and frequency must match the data on the rating plate. Voltage differences of ±5% and/or frequency differences of ±2% are permissible as described in sector A in accordance with EN 60034-1. We ask that you note this when connecting the motors.

A connection diagram is enclosed with each motor upon delivery. Connection of the motor and the control system, as well as overload protection and earthing, must be done in accordance with the VDE and installation instructions and the EVU provisions.

The direction of rotation of the shaft end on the output side must be checked before commissioning. Reversal of the direction of rotation is possible by swapping any two voltage phases.

The insertion parts intended for tension relief or as anti-rotation protection for the supply lines must be used properly. Seal any openings which are not required.

Tightening torques for terminal board connection screw connections (see page 11)

3.7 Motor protection

3.7.1 Thermistor

Connect the built-in thermistor to the tripping device in accordance with the connection diagram in the terminal box cover or provided with the motor. Only carry out any continuity tests which may be required with a measuring bridge (max. 2.5 V).

3.8 Commissioning

⚠ Caution	
	<p>The surface of the drive may reach high temperatures during operation.</p> <p>Danger of burns</p> <ul style="list-style-type: none"> ▶ Secure hot surfaces against operation or unintentional contact. To this end, attach covers or warning according to the regulations. ▶ Allow the motor to cool sufficiently before commencing any work.

Installation of the transmission elements

Only use appropriate tools and devices for fitting and removing the transmission elements. No pressure or impacts may be transmitted to the motor bearings.

Alignment during coupling operation

During coupling operation, the shafts must be axially and radially aligned against each other. Adjustment of the air between the coupling halves must be done in accordance with the coupling manufacturer's specifications.

Use only couplings which are flexible in terms of centre offset, angle, length and torsion. Rigid couplings are not permitted and may only be used in exceptional cases after consultation with the manufacturer.

Before commissioning, the following at a minimum must be checked:

- The runners can be turned without scraping,
- The motor is properly aligned and installed,
- The drive elements have the correct settings,
- All electrical connections, connection elements and mounting screws are properly tightened and implemented,

- Additional devices which are present (e.g. brakes) are functional,
- The coolant supply is not restricted,
- Measures have been taken to protect against contact with moving and live parts.

4 Maintenance

⚠ Danger	
	<p>Installations and work may only be carried out with the device deenergised (separated from the mains) and the motor shut down.</p> <p>Death, cardiac arrhythmia</p> <p>▶ Observe the 5 safety rules, see chapter List of safety and installation notes on page 5</p>

4.1 Inspection

Depending on the level of the contamination, the entire surfaces of the motors should be cleaned. In most cases, the first inspection should be carried out after approx. 500 operating hours, after 1 year at the latest. Follow-up inspections should be carried out within appropriate intervals based on application conditions, for instance re-lubrication or re-greasing, however at least once a year. Accumulating dust should also be removed every now and then.

During inspection, it should be checked whether

- the technical data is observed in accordance with the rating plate,
- there are no leaks (oil, grease, water),
- the operating noises of the bearings as well as the smooth running of the motor have not deteriorated,
- all mounting screws for electrical and mechanical connections are tight,
- the connection of cable screws on the terminal box is fixed properly. If the cable screws are loose, the strain relief (if present) should be loosened and then, the cable screw should be tightened until the cable can no longer move. Tightening the cable screw too firmly will cause constrictions in the cable and should absolutely be prevented. After successful tightening, the strain relief (if present) should be refastened.
- the alignment of the motor is within the approved tolerances during coupling operation.
- any accumulated dust is removed.

4.2 Bearings

4.2.1 Bearings with permanent lubrication

The motor bearings with permanent lubrication are maintenance-free under normal operating conditions for 10000 to 20000 operating hours, but not longer than 3 years.

4.2.2 Bearings with re-lubrication

For motors with a re-lubrication device, the re-lubrication interval, grease quantity and grease quality are specified on an additional label on the motor.

The prescribed lubrication intervals are shorter under extreme loads and/or at increased temperatures. If the number of operating hours specified on the lubrication plate is not reached within 3 years, then re-lubrication should be carried out early. Re-lubrication should be done with the shaft turning.

Lubricants see page 11

After approx. 15000 operating hours, or 3 years at the longest, the grease should be replaced owing to ageing and excessive lubrication of the bearings. Here, inspect the bearings and replace if necessary.

Mixing of different grease types must be avoided!



Caution

When re-lubricating the bearings, the grease drain screws on the DE side and NDE side bearing plate, where present, must always be opened!



Cleaning intervals

The regular removal of old grease is necessary in order not to negatively affect the expected service life of the bearings.

Note



It must be ensured that the running tracks of the bearing and the rolling elements are not damaged during the cleaning process. Do not use metal tools as aids. Make sure there is no dust or dirt near the rolling element or in the rolling element!

This causes a drastic shortening in service life!

For further instructions, see chapter Repair

4.3 Repair

Spare parts lists and regular drawings do not contain the types and dimensions of the parts. Therefore, the type and dimensions of the concerned parts should be determined during disassembly and they should be marked for assembly.

4.3.1 Joint sealing

For motors with protection class IP56 or higher (see rating plate), the part joints between the motor housing and the bearing plates should be sealed with a suitable, non-hardening sealing mass.

5 Spare parts

For spare parts orders, the motor type and motor number (details can be found on the rating plate) must always be specified in addition to the exact part designation.

With the exception of standardised commercially available and equivalent parts, e.g. ball bearings, only original parts may be used.

This applies in particular for seals and terminals.

6 Final decommissioning (disassembly, recycling, disposal)

Always disassemble motors in such a way that environmentally-friendly recycling and disposal of the motor components is possible.

When recycling and disposing of the disassembled motor components, always observe the legal regulations and provisions applicable at the time of the final decommissioning!

7 Appendix

Operating conditions	Insulation class	Roller bearing grease / area of application
Normal	F	High-temperature and long-term lubricant -40 °C to +180 °C
High temperatures, extreme operating conditions	H	High-temperature and long-term lubricant -20 °C to +180 °C
Low temperatures	F	Low-temperature lubricant -50 °C to +150 °C

Table 1: Lubricants

Thread \varnothing		M4	M5	M6	M8	M10	M12	M16
Tightening torque	min.	0.8	1.8	2.7	5.5	9.0	14.0	27.0
	max.	1.2	2.5	4.0	8.0	13.0	20.0	40.0

Table 2: Tightening torques for terminal board connection screw connections

The tightening torques apply provided no other values are specified!

Part no.	Description
1.0	Housing (IMB3)
1.1	Housing without feet (IMB5 / IMB14)
1.2	Motor feet
2.0	Stator package with winding
3.1	Rotor with shaft
4.0	Bearing plate AS (IMB3)
4.1	Flange bearing plate (IMB5)
4.2	Flange bearing plate (IMB14)
5.1	Bearing plate BS
6.0	Bearing cover ASi
6.1	Bearing cover ASa
6.2	Bearing cover BSi
6.3	Bearing cover BSa
6.4	Centrifugal disc
7.0	Fan (thermoplastic)
7.1	Fan (aluminium alloy)
8.2	Fan cover
8.3	Protective roof (IMV1)
9.2	Terminal box frame
9.3	Terminal box frame sealing
10.0	Terminal board, complete
11.2	Terminal box cover
11.3	Terminal box cover sealing
12.0	Rolling bearing AS
12.1	Rolling bearing BS
13.0	Shaft seal ring
13.1	Shaft seal ring
14.0	Securing ring (rolling bearing)
14.1	Securing ring (rolling bearing)
14.2	Securing ring (fan)
14.3	Securing ring (brake)
15.0	Spring plate
16.0	Ring bolt
17.1	Cable screw
18.0	Brake, complete
18.1	Brake disc
18.2	Armature plate
18.3	Magnet part
18.4	Compression spring
18.5	Pressure piece
18.6	Adjustment ring
18.7	Manual ventilation, complete
18.8	Terminal strip
18.9	Rectifier
18.10	Friction plate
18.11	Cylinder screw
18.12	Re-adjustment sleeve

Table 3: Spare parts

Order example: Frame size: 160L
 Motor no.: 3574507
 Part: 3.1 rotor with shaft

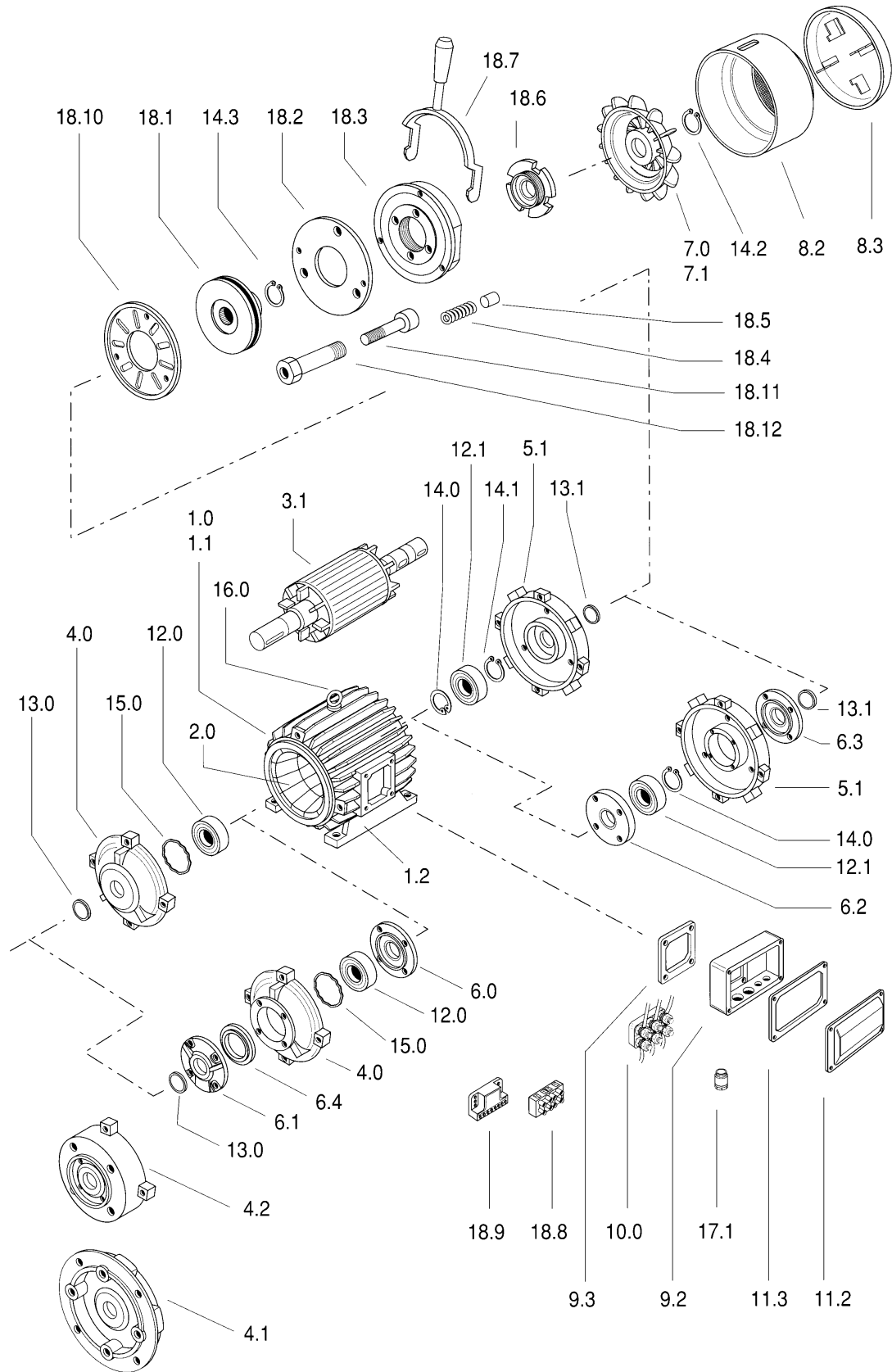

8 Declaration of conformity

EC Declaration of conformity

Document no./month/year : 1.51.821.010/06.22
Manufacturer : EMOD Motoren GmbH
Address : Zur Kuppe 1
D-36364 Bad Salzschlirf
Product description : Three-phase motors
Type (frame size) : HEF IE2 56L/.. - HEF IE2 450L/..
HEF IE3 56L/.. - HEF IE3 450L/..

Three-phase motors in accordance with Directive 2009/125/EG, Regulation (EU) No. 2019/1781 and Regulation (EU) No. 4/2014

The designated product is in compliance with the stipulations set forth in the following European directives:

2014/35/EU

Directive 2014/35/EU of the European Parliament and the Council on the harmonisation of the laws of the Member States relating to the making available on the market of electrical equipment designed for use within certain voltage limits (recast)

2014/30/EU

Directive 2014/30/EU of the European Parliament and the Council on the harmonisation of the laws of the Member States relating to electromagnetic compatibility (recast)

The designated product has been developed and produced in compliance with the following standards:

EN 60034-1: 2010 + Cor.: 2010	EN IEC 60034-5: 2020	EN 60034-6: 1993
EN 60034-9: 2005 + A1: 2007	EN IEC 61000-6-1: 2019	EN IEC 61000-6-2: 2019
EN IEC 61000-6-3: 2021	EN IEC 61000-6-4: 2019	EN 60204-1: 2018
EN IEC 60034-30-1: 2014		

First establishment of the CE certification: 2010

Issuer: : EMOD Motoren GmbH
Place, date : Bad Salzschlirf, 28.06.2022
Management : 

Roland Odenwald

This declaration certifies compliance with the above-mentioned directives and standards, but is no assurance of characteristics in the sense of the product liability.

The safety instructions in the operating manual supplied must be observed.

9 Documents provided

- [Circuit diagram](#)

Anschlussschaltbild(er)
Connection diagram(s)

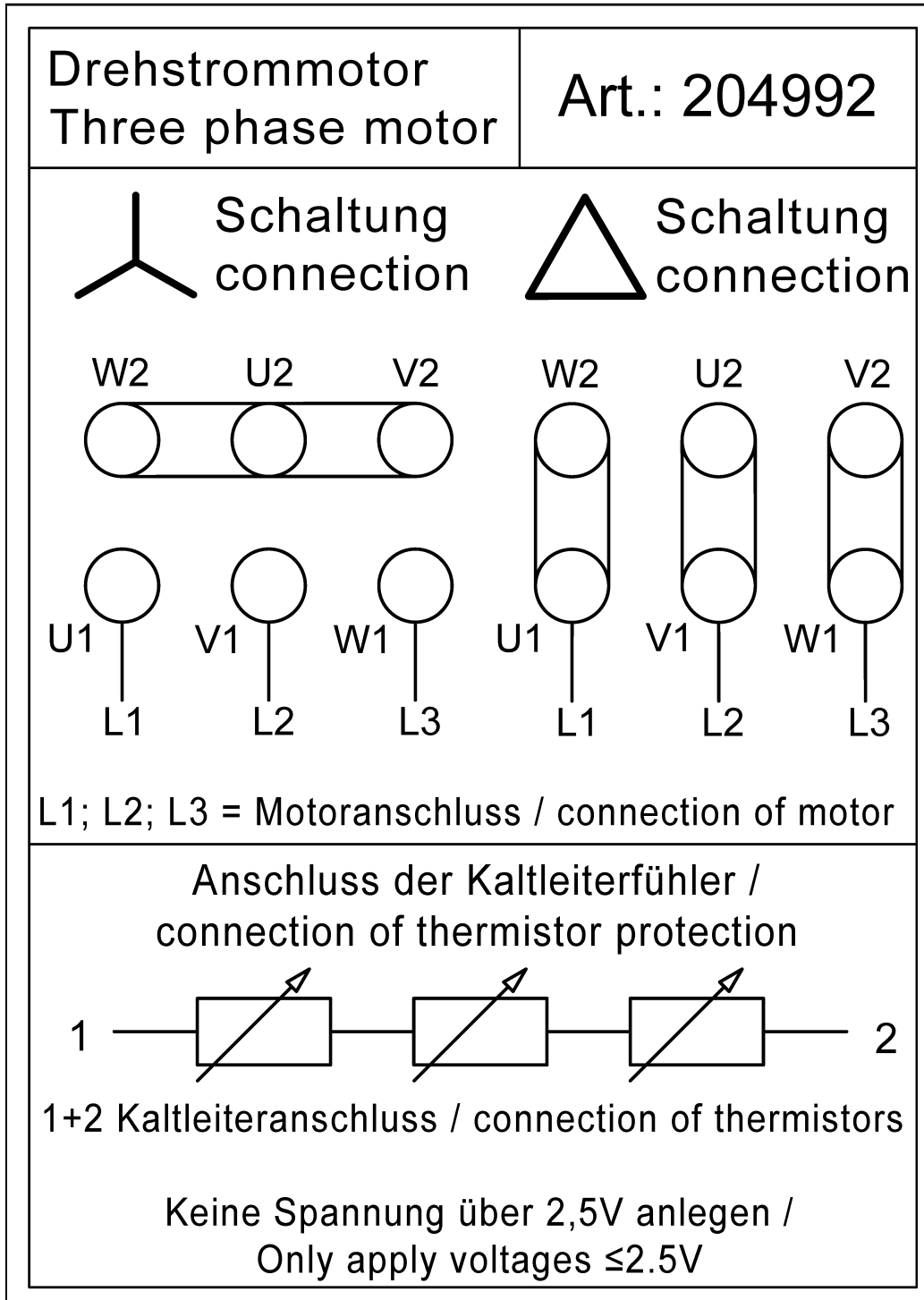

Hausanschrift/ address:
Zur Kuppe 1
D- 36364 Bad Salzschlirf

Tel. 06648 51-0
Fax. 06648 51-143
info@emod-motoren.de
www.emod-motoren.de

EC Declaration of conformity

Document no./month/year : 1.51.821.010/06.22
Manufacturer : EMOD Motoren GmbH
Address : Zur Kuppe 1
D-36364 Bad Salzschlirf
Product description : Three-phase motors
Type (frame size) : HEF IE2 56L.. - HEF IE2 450L..
HEF IE3 56L.. - HEF IE3 450L..

Three-phase motors in accordance with Directive 2009/125/EG, Regulation (EU) No. 2019/1781 and Regulation (EU) No. 4/2014

The designated product is in compliance with the stipulations set forth in the following European directives:

2014/35/EU

Directive 2014/35/EU of the European Parliament and the Council on the harmonisation of the laws of the Member States relating to the making available on the market of electrical equipment designed for use within certain voltage limits (recast)

2014/30/EU

Directive 2014/30/EU of the European Parliament and the Council on the harmonisation of the laws of the Member States relating to electromagnetic compatibility (recast)

The designated product has been developed and produced in compliance with the following standards:

EN 60034-1: 2010 + Cor.: 2010	EN IEC 60034-5: 2020	EN 60034-6: 1993
EN 60034-9: 2005 + A1: 2007	EN IEC 61000-6-1: 2019	EN IEC 61000-6-2: 2019
EN IEC 61000-6-3: 2021	EN IEC 61000-6-4: 2019	EN 60204-1: 2018
EN IEC 60034-30-1: 2014		

First establishment of the CE certification: 2010

Issuer: : EMOD Motoren GmbH
Place, date : Bad Salzschlirf, 28.06.2022
Management : 

Roland Odenwald

This declaration certifies compliance with the above-mentioned directives and standards, but is no assurance of characteristics in the sense of the product liability.

The safety instructions in the operating manual supplied must be observed.

Operating manual for single-phase motors

Frame size 56 ... 112 EHB / EARZ

Issue:1.0 - 11/19



© All rights reserved

EMOD Motoren GmbH

Electric motor factory

Zur Kuppe 1

36364 Bad Salzschlirf

Germany

Phone: +49 6648 51-0

Fax: +49 6648 51-143

info@emod-motoren.de

www.emod-motoren.de

Table of contents

1	General information	4
1.1	Area of application	4
1.2	Explanation of the labels used	4
1.3	List of safety and installation notes	5
1.4	Limitation of liability	5
1.5	Safety	6
1.6	Series (brief description)	6
2	Transportation and storage	6
2.1	Transportation	6
2.2	Storage	7
3	Installation and commissioning	7
3.1	Positioning	7
3.1.1	Location	7
3.2	Mountings for motors	7
3.3	Condensation drain holes	7
3.4	Balancing	8
3.5	Insulation resistance check	8
3.6	Electrical connection	8
3.7	Motor protection	8
3.7.1	Temperature switch NC	8
3.8	Commissioning	9
4	Maintenance	9
4.1	Inspection	9
4.2	Bearings	10
4.2.1	Bearings with permanent lubrication	10
4.3	Repair	10
4.3.1	Joint sealing	10
5	Spare parts	10
6	Final decommissioning (disassembly, recycling, disposal)	10
7	Appendix	11
8	Declaration of conformity	14
9	Documents provided	15









1 General information

Note	
	<p>The safety instructions contained in this operating manual must be observed!</p> <p>Special designs and structural variants may differ from the basic type in terms of technical details. If there are any uncertainties, we strongly advise you to contact EMOD Motoren GmbH. Always state the motor type and motor number.</p>

1.1 Area of application

The motors can be used in accordance with the protection class stamped on the rating plate, the type of construction intended by the manufacturer according to the catalogue or the customer's information. When using custom motors, the information in the quote and order confirmation also applies.

1.2 Explanation of the labels used

Symbol	Meaning
 Danger	Indicates an immediate danger to life and health. Results in death or serious injury if not prevented.
 Warning	Indicates a possible danger to life and health. May result in death or serious injury if not prevented
 Caution	Indicates a possible danger to life and health. May result in slight or minor injuries if not prevented.
Note	Indicates a potentially harmful situation. The system or things in the surrounding area may be damaged if not prevented.
	Warning of a danger (general). The type of danger is specified by the accompanying warning text.
	Warning of dangerous electrical voltage and its effect.
	Warning of hot surface.
	Warning of suspended load.
	Warning of explosive atmosphere.

1.3 List of safety and installation notes



Caution

Electric motors have dangerous, live and rotating parts. All work during connection, commissioning, maintenance and disposal may only be carried out by qualified professionals. (Observe EN 50110-1 and IEC 60364) Before beginning any work, any in particular before opening covers, the drive must be isolated according to regulations. In addition to the main circuit, any auxiliary circuits which may be present must be taken into account here.

Compliance with the 5 safety rules:

- Isolate
- Secure against being switched on again
- Establish the absence of voltage
- Earth and short-circuit
- Cover or block off adjacent live parts

The measures specified above may only be withdrawn after the work has been completed and the drive is fully installed. Improper conduct may result in injuries and property damage. The applicable national, local and system-specific provisions and requirements must be observed and complied with.



Warning

The proper and safe operation of the products assumes proper transportation, proper storage, positioning and installation, and careful operation and maintenance.



Caution

The surfaces of the motors may be ≥ 55 °C during operation! The hot surfaces should not be touched.



Note

Products with a weight of ≥ 20 kg should only be moved and lifted with appropriate lifting devices.

1.4 Limitation of liability

All information and instructions in this manual have been put together taking the applicable standards and regulations, the state of the art and our many years of knowledge and experience into account.

The manufacturer assumes no liability for damage resulting from:

- Failure to observe the manual
- Improper use
- Use of untrained personnel
- Unauthorised modifications
- Technical modifications
- Use of unapproved spare parts

The obligations agreed in the supply contract, the general terms and conditions, as well as the manufacturer's delivery conditions, and the applicable statutory provisions at the time of signing of the contract apply.

We reserve the right to make technical changes within the context of the performance characteristics and further development.

1.5 Safety

⚠ Warning	
	Installation, commissioning and maintenance may only be carried out by personnel with suitable training and qualifications.

In this respect, special attention should be paid to:

- the technical data and information concerning the proper use (commissioning, environmental and operational conditions), which are stated in the catalogue, the operation manual, the rating plates and the additional product documentation,
- the relevant construction and accident prevention regulations,
- the correct use of tools, lifting and transport devices,
- the implementation of protection measures against unintentional contact when installed to prevent endangerment of persons due to moving parts,
- the use of personal protective equipment.

1.6 Series (brief description)

EHB

Single-phase motor with working and auxiliary winding
 M_A/M_N approx. 0.3 - 0.7

EARZ

Single-phase motor with working and auxiliary winding, with operating and start-up capacitor.
 The start-up capacitor is switched off after successful start-up by a timer-controlled relay. The start-up time is adjustable.
 M_A/M_N approx. 1.5 - 2.0

2 Transportation and storage

⚠ Warning	
	<p>Danger due to heavy loads severe injuries and property damage possible</p> <ul style="list-style-type: none"> ▶ Products with a weight of ≥ 20 kg should only be moved and lifted with appropriate lifting devices ▶ Only use the intended lifting eyes for transportation of the fully assembled drive unit ▶ Do not lift the complete drive unit at the motor transport eyes

2.1 Transportation

The motors must be inspected for transport damage upon receipt. Any possible damage should be documented in detail in writing.

Motors with cylindrical roller bearings are protected against bearing damage by transport protection. The transport protection must be removed before raising of the transfer elements and commissioning.

2.2 Storage

The storage location should be as dry, clean, stable in temperature and free from vibrations as possible.

So that the lubrication film in the motor bearings and the sealing systems is not stripped off, the motor shaft should be turned a few times by hand, e.g. at monthly intervals, during long storage periods.

The motor rolling bearings should be re-greased or replaced if the period between delivery and commissioning is more than 4 years. In unfavourable storage conditions, this period is significantly reduced.

3 Installation and commissioning

⚠ Danger	
	<p>Installations and work may only be carried out with the device deenergised (separated from the mains) and the motor shut down.</p> <p>Death, cardiac arrhythmia</p> <p>► Observe the 5 safety rules, see chapter List of safety and installation notes on page 5</p>

3.1 Positioning

3.1.1 Location

The motors should be installed/fitted while easily accessible and at an ambient or coolant temperature of max. +50°C. Higher coolant or ambient temperatures of up to 60 °C, with corresponding power reduction, are possible after consultation with the manufacturer.

The cooling air should be able to flow in and out unhindered and should not be directly sucked in again. The air inlets and outlets, as well as the channels between the cooling ribs, should be protected against dust and dirt and regularly cleaned.

If the product is installed with the shaft end upwards or downwards, it should be guaranteed that no water can penetrate the upper bearing.

3.2 Mountings for motors

Foot-mounting motors must be positioned and mounted on an even, vibration-free surface. All mounting feet must lie flat; place thin sheets underneath for levelling if necessary.

For flange motors, care must be taken to ensure the axial run-out of the counterflange. Axial run-out errors may result in bearing damage and/or the failure of sealing systems.

3.3 Condensation drain holes

Care must be taken to ensure that the available condensation drain holes are located at the lowest point of the motor after installation and are kept free from dirt.

Closed condensation drain holes (if present) should be opened from time to time and closed again before each start-up.

3.4 Balancing

⚠ Danger	
	<p>Rotating parts Severe injuries</p> <p>▶ Secure feather keys against being ejected</p>

The balancing type is indicated on the shaft end face of the motor shafts in accordance with DIN ISO 8821:

- Balancing with a half key “H”
- Balancing with a full key “F”

Observe the appropriate balancing type when installing the drive element!

3.5 Insulation resistance check

Before commissioning of the motor, or after a longer storage period or downtime (more than 6 months), the insulation resistance of the winding should be checked. Check the winding against mass by means of an insulation resistance measuring device (max. DC voltage 500 V). If the minimum insulation resistance at a winding temperature of 25 °C is smaller than 30 MΩ, or smaller than 1 MΩ at a winding temperature of 75 °C, the motor winding should be dried until the required minimum insulation resistance is reached. The winding temperature should not exceed 80 °C in this regard! Loosen the bearing plate, so that an air exchange can be carried out with closed motors. After the winding has been dried out, the bearing needs to be serviced (see corresponding chapter!).

3.6 Electrical connection

The mains voltage and frequency must match the data on the rating plate. Voltage differences of $\pm 5\%$ and/or frequency differences of $\pm 2\%$ are permissible as described in sector A in accordance with EN 60034-1. We ask that you note this when connecting the motors.

Motor switch-off must be done through complete disconnection of all phases from the power supply.

A connection diagram is enclosed with each motor upon delivery. Connection of the motor and the control system, as well as overload protection and earthing, must be done in accordance with the VDE and installation instructions and the EVU provisions.

The direction of rotation of the shaft end on the output side must be checked before commissioning. Reversal of the direction of rotation should be done in accordance with the attached connection diagram.

The insertion parts intended for tension relief or as anti-rotation protection for the supply lines must be used properly. Seal any openings which are not required.

Tightening torques for terminal board connection screw connections see page 11.

3.7 Motor protection

3.7.1 Temperature switch NC

If a temperature monitor is provided as a temperature switch NC for motor protection, then this must be connected in series with the auxiliary circuit in accordance with the connection diagram (min. 25 max. 250 V 1.6 A).

3.8 Commissioning

⚠ Caution	
	<p>The surface of the drive may reach high temperatures during operation. Danger of burns</p> <ul style="list-style-type: none"> ▶ Secure hot surfaces against operation or unintentional contact. To this end, attach covers or warning according to the regulations. ▶ Allow the motor to cool sufficiently before commencing any work.

Installation of the transmission elements

Only use appropriate tools and devices for fitting and removing the transmission elements. No pressure or impacts may be transmitted to the motor bearings.

Alignment during coupling operation

During coupling operation, the shafts must be axially and radially aligned against each other. Adjustment of the air between the coupling halves must be done in accordance with the coupling manufacturer's specifications.

Use only couplings which are flexible in terms of centre offset, angle, length and torsion. Rigid couplings are not permitted and may only be used in exceptional cases after consultation with the manufacturer.

Before commissioning, the following at a minimum must be checked:

- The runners can be turned without scraping,
- The motor is properly aligned and installed,
- The drive elements have the correct settings,
- All electrical connections, connection elements and mounting screws are properly tightened and implemented,
- Additional devices which are present (e.g. brakes) are functional,
- The coolant supply is not restricted,
- Measures have been taken to protect against contact with moving and live parts.

4 Maintenance

⚠ Danger	
	<p>Installations and work may only be carried out with the device deenergised (separated from the mains) and the motor shut down. Always discharge capacitors since these may retain a residual voltage which is hazardous to humans even after the motor is switched off!</p> <p>Death, cardiac arrhythmia</p> <ul style="list-style-type: none"> ▶ Observe the 5 safety rules, see chapter List of safety and installation notes on page 5

4.1 Inspection

Depending on the level of the contamination, the entire surfaces of the motors should be cleaned.

In most cases, the first inspection should be carried out after approx. 500 operating hours, after 1 year at the latest. Follow-up inspections should be carried out within appropriate intervals based on application conditions, for instance re-lubrication or re-greasing, however at least once a year.

Accumulating dust should also be removed every now and then.

During inspection, it should be checked whether

- the technical data is observed in accordance with the rating plate,
- there are no leaks (oil, grease, water),
- the operating noises of the bearings as well as the smooth running of the motor have not deteriorated,
- all mounting screws for electrical and mechanical connections are tight,
- the connection of cable screws on the terminal box is fixed properly. If the cable screws are loose, the strain relief (if present) should be loosened and then, the cable screw should be tightened until the cable can no longer move. Tightening the cable screw too firmly will cause constrictions in the cable and should absolutely be prevented. After successful tightening, the strain relief (if present) should be refastened.
- the alignment of the motor is within the approved tolerances during coupling operation.
- any accumulated dust is removed.

4.2 Bearings

4.2.1 Bearings with permanent lubrication

The motor bearings with permanent lubrication are maintenance-free under normal operating conditions for 10.000 to 20.000 operating hours, but not longer than 3 years.

Lubricants see page 11.

Mixing of different grease types must be avoided!

4.3 Repair

Spare parts lists and regular drawings do not contain the types and dimensions of the parts. Therefore, the type and dimensions of the concerned parts should be determined during disassembly and they should be marked for assembly.

4.3.1 Joint sealing

For motors with protection class IP56 or higher (see rating plate), the part joints between the motor housing and the bearing plates should be sealed with a suitable, non-hardening sealing mass.

5 Spare parts

For spare parts orders, the motor type and motor number (details can be found on the rating plate) must always be specified in addition to the exact part designation.

With the exception of standardised commercially available and equivalent parts, e.g. ball bearings, only original parts may be used.

This applies in particular for seals and terminals.

6 Final decommissioning (disassembly, recycling, disposal)

Always disassemble motors in such a way that environmentally-friendly recycling and disposal of the motor components is possible.

When recycling and disposing of the disassembled motor components, always observe the legal regulations and provisions applicable at the time of the final decommissioning!

7 Appendix

Operating conditions	Insulation class	Roller bearing grease / area of application
Normal	F	High-temperature and long-term lubricant -40 °C to +180 °C
High temperatures, extreme operating conditions	H	High-temperature and long-term lubricant -20 °C to +180 °C
Low temperatures	F	Low-temperature lubricant -50 °C to +150 °C

Table 1: Lubricants

Thread \varnothing		M4	M5	M6	M8	M10	M12	M16
Tightening torque	min.	0.8	1.8	2.7	5.5	9.0	14.0	27.0
	max.	1.2	2.5	4.0	8.0	13.0	20.0	40.0

Table 2: Tightening torques for terminal board connection screw connections

The tightening torques apply provided no other values are specified!

Part no.	Designation
1.0	Housing (IMB3)
1.1	Housing without feet (IMB5 / IMB14)
1.2	Motor feet
2.0	Stator package with winding
3.1	Rotor with shaft
4.0	Bearing plate DE side (IMB3)
4.1	Flange bearing plate (IMB5)
4.2	Flange bearing plate (IMB14)
5.1	Bearing plate NDE side
6.0	Bearing cover ASi
6.1	Bearing cover ASa
6.2	Bearing cover BSi
6.3	Bearing cover BSa
6.4	Centrifugal disc
7.0	Fan
8.2	Fan cover
9.2	Terminal box frame
9.3	Terminal box frame sealing
10.0	Terminal board, complete
11.2	Terminal box cover
11.3	Terminal box cover sealing
12.0	Rolling bearing DE side
12.1	Rolling bearing NDE side
13.0	Shaft seal ring
13.1	Shaft seal ring
14.0	Securing ring (rolling bearing)
14.1	Securing ring (rolling bearing)
14.2	Securing ring (fan)
15.0	Spring plate
16.0	Ring bolt
17.1	Cable screw
19.0	Capacitor (single-phase motors)

3 :Spare parts list

Order example: Frame size: 160L
 Motor no.: 3574507
 Part: 3.1 rotor with shaft

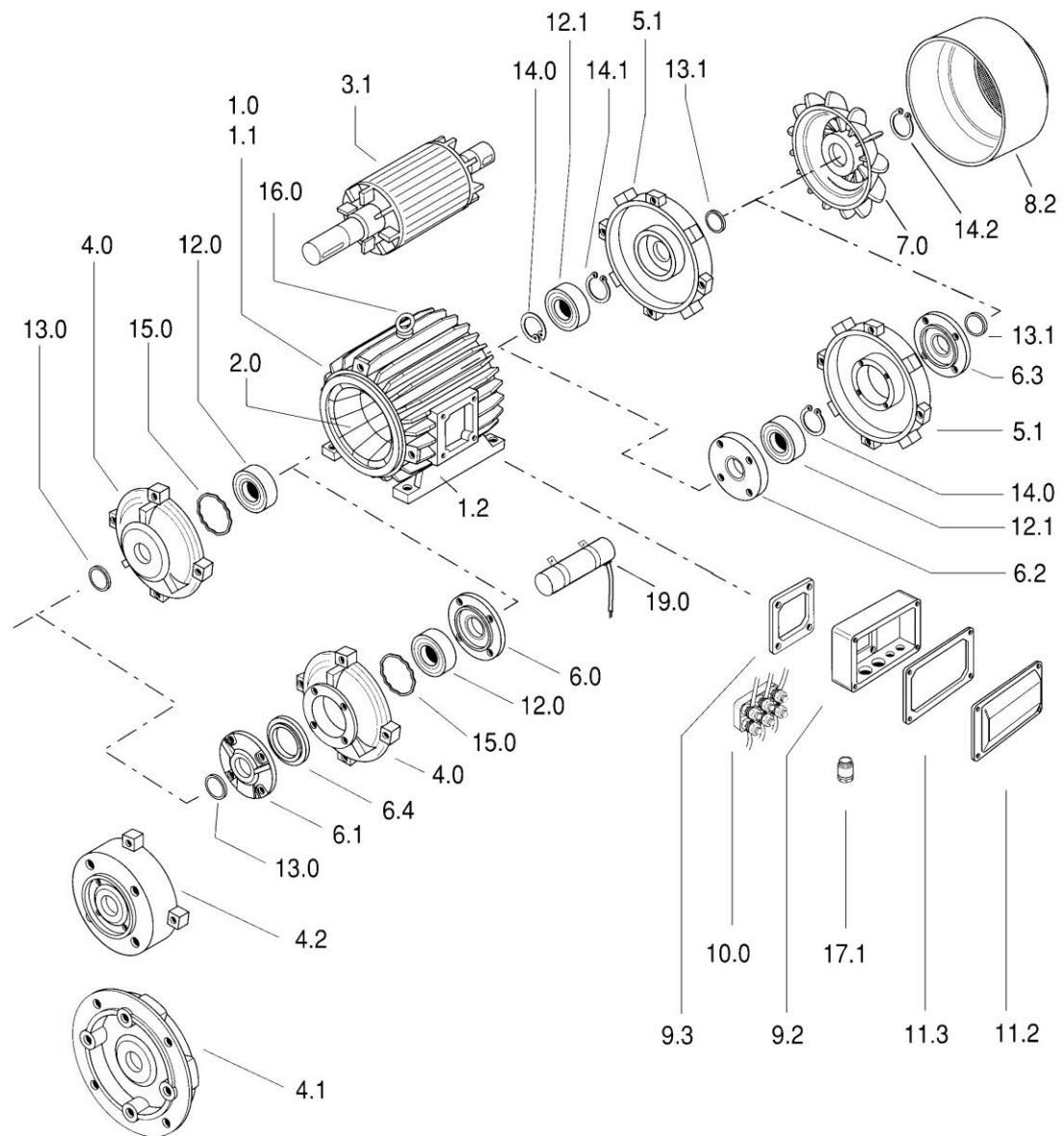

8 Declaration of conformity

EC Declaration of conformity

Document no./month/year : 1.51.820.001/06.22
Manufacturer : EMOD Motoren GmbH
Address : Zur Kuppe 1
D-36364 Bad Salzschlirf
Product description : Single phase motors
Type (frame size) : 56 EHB.. - 112 EHB..
56 EAZR.. - 112 EAZR..

The designated product is in compliance with the stipulations set forth in the following European directives:

2014/35/EU

Directive 2014/35/EU of the European Parliament and the Council on the harmonisation of the laws of the Member States relating to the making available on the market of electrical equipment designed for use within certain voltage limits (recast)

2014/30/EU

Directive 2014/30/EU of the European Parliament and the Council on the harmonisation of the laws of the Member States relating to electromagnetic compatibility (recast)

The designated product has been developed and produced in compliance with the following standards:

EN 60034-1: 2010 + Cor.: 2010	EN IEC 60034-5: 2020	EN 60034-6: 1993
EN 60034-9: 2005 + A1: 2007	EN IEC 61000-6-1: 2019	EN IEC 61000-6-2: 2019
EN IEC 61000-6-3: 2021	EN IEC 61000-6-4: 2019	EN 60204-1: 2018

First establishment of the CE certification: 1996

Issuer: : EMOD Motoren GmbH
Place, date : Bad Salzschlirf, 28.06.2022

Management :



Roland Odenwald

This declaration certifies compliance with the above-mentioned directives and standards, but is no assurance of characteristics in the sense of the product liability.

The safety instructions in the operating manual supplied must be observed.

9 Documents provided

- [Circuit diagram](#)

Anschlußschaltbild(er)
Connection diagram(s)

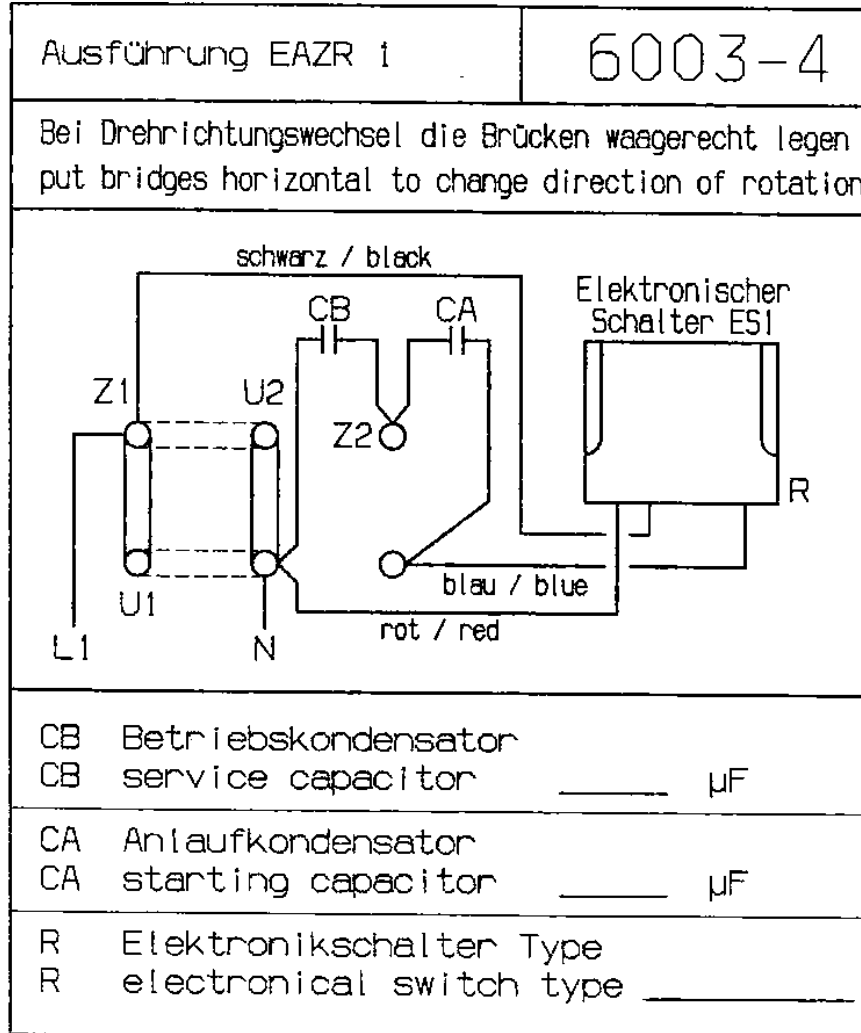

Hausanschrift/ address:
Zur Kuppe 1
D- 36364 Bad Salzschlirf

Tel. 06648 51-0
Fax. 06648 51-143
info@emod-motoren.de
www.emod-motoren.de

Anschlußschaltbild(er)
Connection diagram(s)

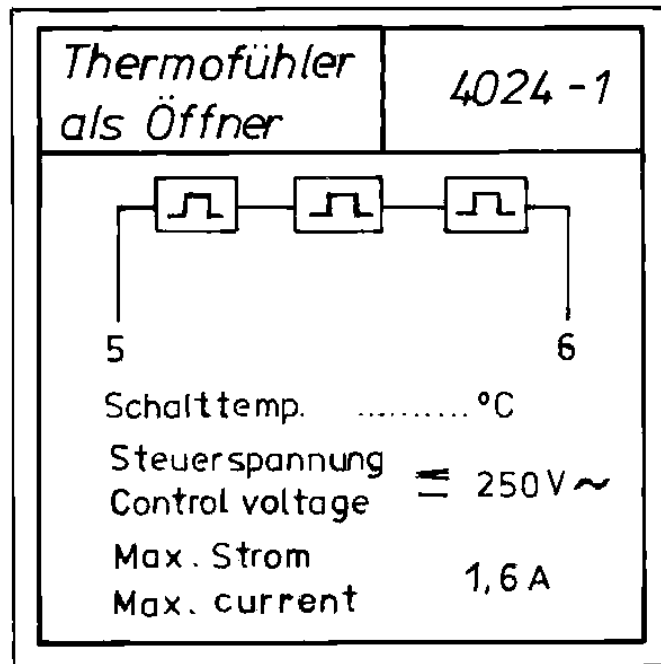

Hausanschrift/ address:
Zur Kuppe 1
D- 36364 Bad Salzschlirf

Tel. 06648 51-0
Fax. 06648 51-143
info@emod-motoren.de
www.emod-motoren.de

8 Declaration of conformity

EC Declaration of conformity

Document no./month/year : 1.51.820.001/06.22
Manufacturer : EMOD Motoren GmbH
Address : Zur Kuppe 1
D-36364 Bad Salzschlirf
Product description : Single phase motors
Type (frame size) : 56 EHB.. - 112 EHB..
56 EAZR.. - 112 EAZR..

The designated product is in compliance with the stipulations set forth in the following European directives:

2014/35/EU

Directive 2014/35/EU of the European Parliament and the Council on the harmonisation of the laws of the Member States relating to the making available on the market of electrical equipment designed for use within certain voltage limits (recast)

2014/30/EU

Directive 2014/30/EU of the European Parliament and the Council on the harmonisation of the laws of the Member States relating to electromagnetic compatibility (recast)

The designated product has been developed and produced in compliance with the following standards:

EN 60034-1: 2010 + Cor.: 2010	EN IEC 60034-5: 2020	EN 60034-6: 1993
EN 60034-9: 2005 + A1: 2007	EN IEC 61000-6-1: 2019	EN IEC 61000-6-2: 2019
EN IEC 61000-6-3: 2021	EN IEC 61000-6-4: 2019	EN 60204-1: 2018

First establishment of the CE certification: 1996

Issuer: : EMOD Motoren GmbH
Place, date : Bad Salzschlirf, 28.06.2022

Management :



Roland Odenwald

This declaration certifies compliance with the above-mentioned directives and standards, but is no assurance of characteristics in the sense of the product liability.

The safety instructions in the operating manual supplied must be observed.

KNF worldwide

You can find our local KNF partners at: www.knf.com