

**Operation Readiness Clearance (ORC)
of
SpinQuest (E1039) UVA-NMR
Part 2 (Custom Components)**

ORC - ####

Dustin Keller, Ishara Fernando & Waqar Ahmed

Table of Contents

1. Introduction.....	(1)
2. Power supply to the Yale-Card and Q-meter.....	(4)
3. Breakout panel.....	(6)
4. DIO (Digital In/Out) box.....	(7)
5. The Box (containing Q-meter & Yale-Card).....	(11)
6. Q-meter.....	(14)
6.1 Q-meter circuitry.....	(14)
6.2 Q-meter schematic.....	(15)
6.3 Q-meter housing.....	(20)
7. Yale-Card.....	(21)
7.1 Yale-Card housing.....	(21)
7.2 Yale-Card circuitry.....	(22)
7.3 Yale-Card schematic.....	(25)
8. Safety.....	(26)
<i>References</i>	(26)

1 Introduction

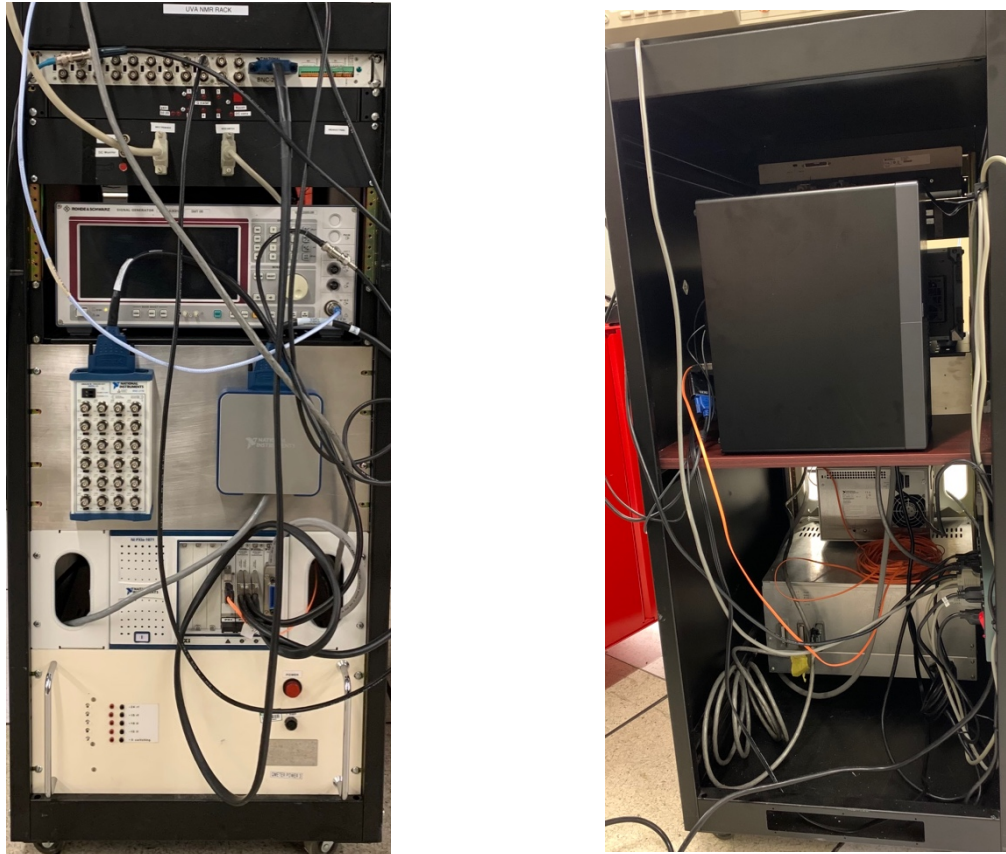

Figure 1.1: UVA-NMR System (front view (left), back view (right))

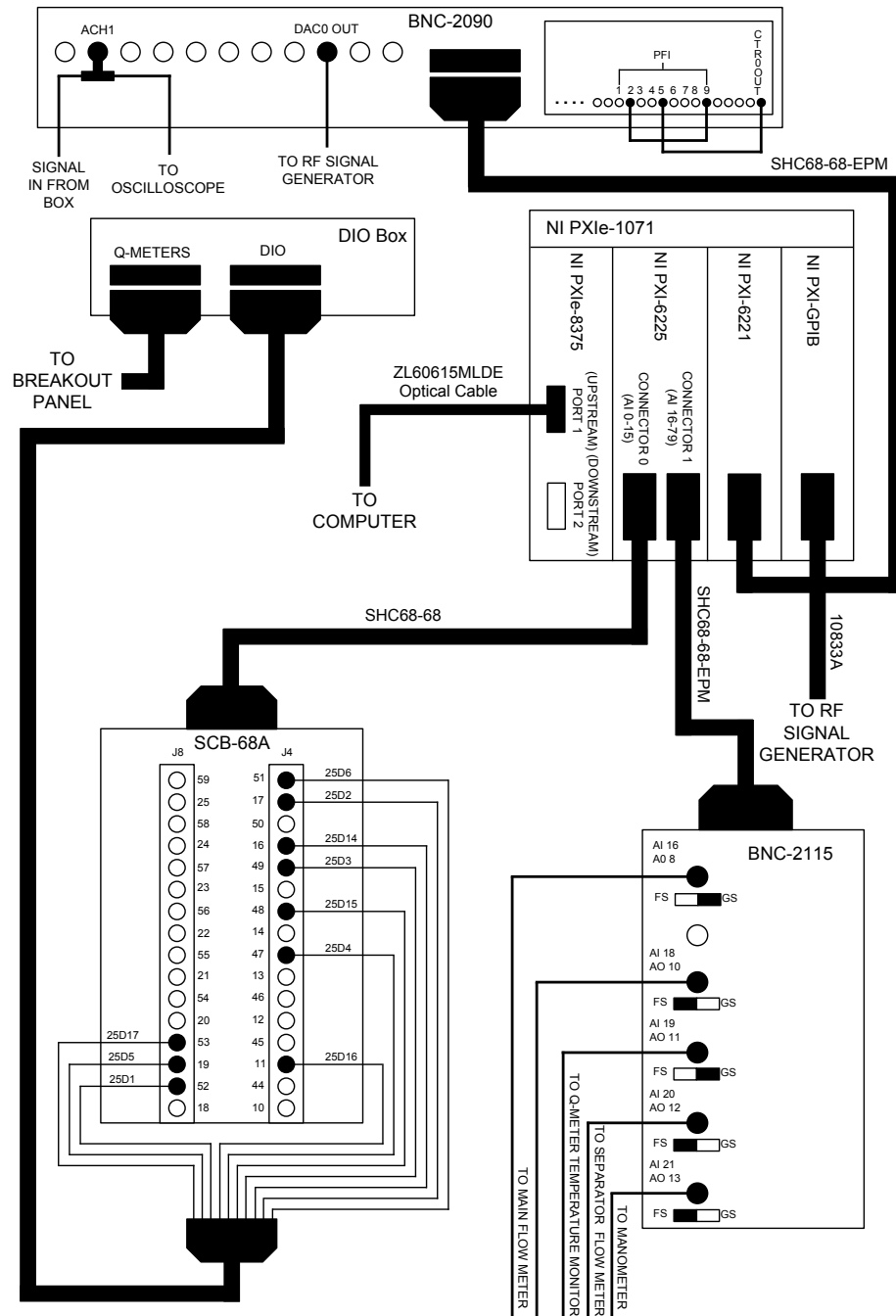

Figure 1.2: UVA-NMR system connections

Component	Voltage (V)	Current (A)	Power (W)
Q-meter and Yale-Card power supply	120	0.3	36.0
DAQ National Instruments (PXle)	120	4.2	504.0
Computer (Dell XPS)	120	4.0	460.0
RF generator (SMT 06)	120	2.7	324.0
Oscilloscope (Tektronics TDS 3032)	120	0.62	74.4
Total			1,398.4

Table 1.1: Power budget

2 Power Supply to the Yale Card and Q-meter

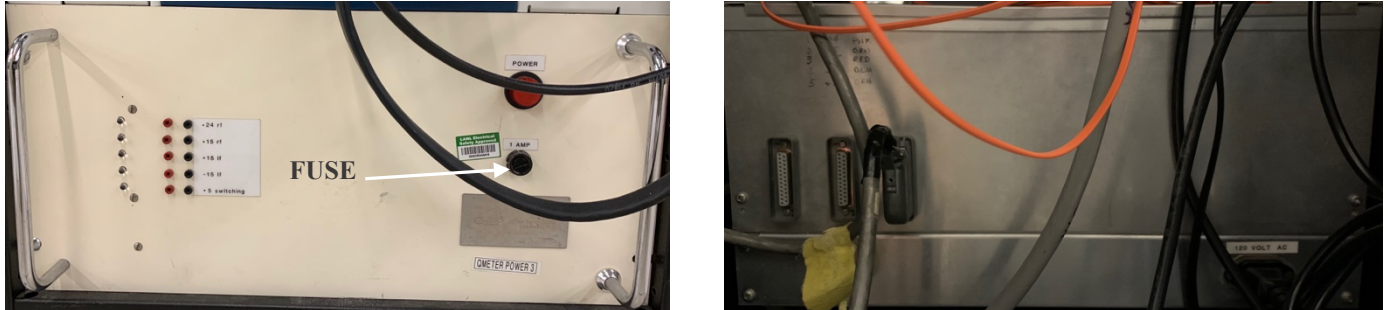

Figure 2.1: Power supply to the Q-meter and Yale-Card

The power supply provides power to the Yale card and Q-meter [1,2,5] through the box. There are three 25-pin D-subminiature (or D-sub) connectors on the back of the power supply to which the power cable of 22 AWG [6] is connected to 25-pin D-sub. The device supplies four unique voltages, +24V, +15V, -15V, and +5V. The wiring of the power supply output is covered in Figure 2.1.

Pin #	Voltage [V]	Pin #	Voltage [V]
1	+24 RF	14	G
2	+15 RF	15	G
3	+15 LF	16	G
4	-15 LF	17	G
5	+5 S	18	G
6	NC	19	NC
7			
8			
9			
10			
11			
12			
13	25		

Table 2.1: Connections to the power supply

The RF (Radio Frequency) and LF (Low Frequency) labels for the voltages in Table 2.1 represent the op-amps inside the Q-meter which are powered by the specific DC voltages. The “S” label stands for “switching” voltage, “G” represents “Ground”, and “NC” represents “Not-Connected”.

Power supply schematic

NMR Power Supply

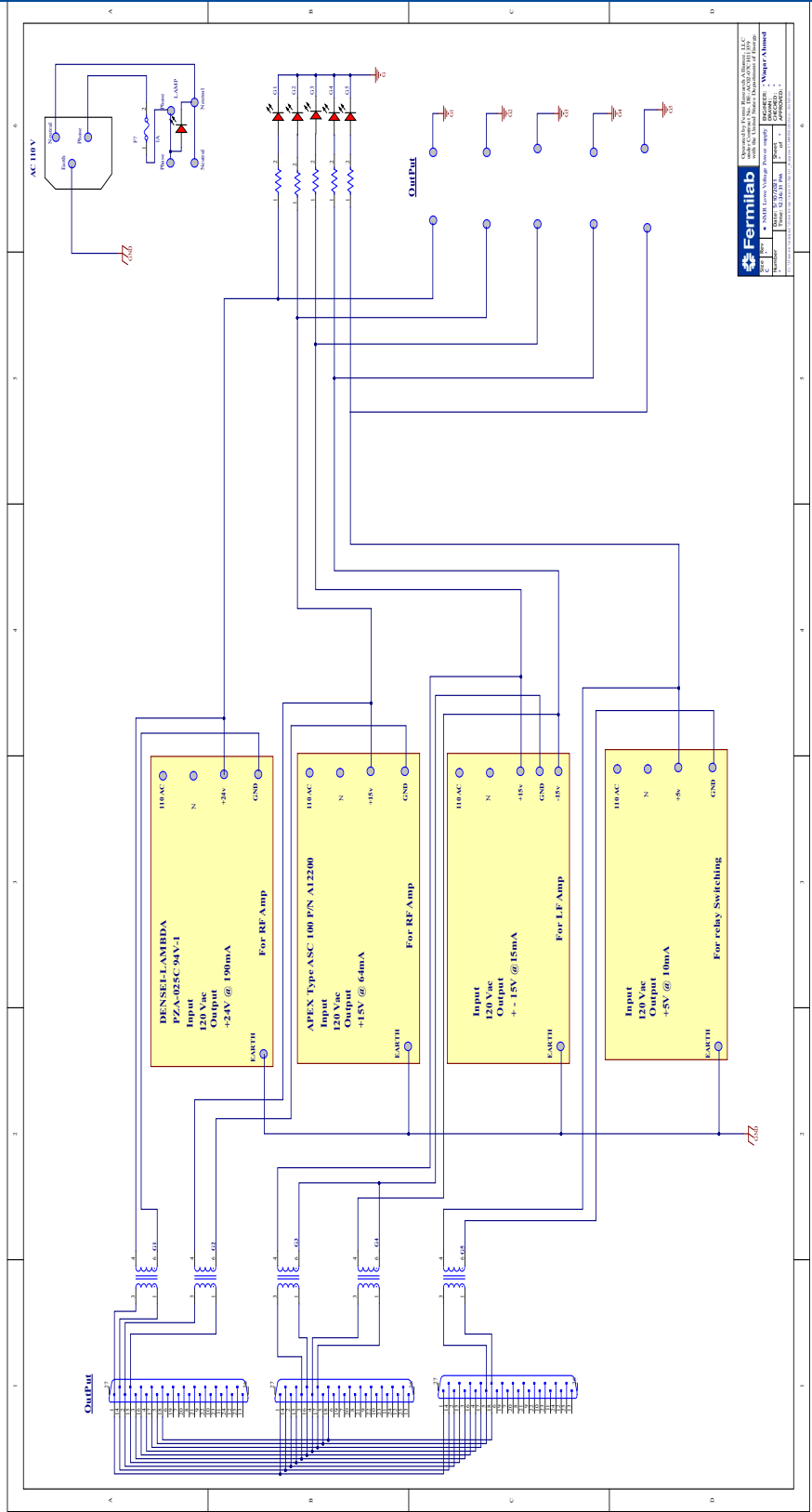

Fermilab
 Fermi National Accelerator Laboratory
 300 North Central Expressway
 Batavia, IL 60007
 Phone: 630/216-2000
 Fax: 630/216-2001
 www.fermilab.gov

3 Breakout Panel

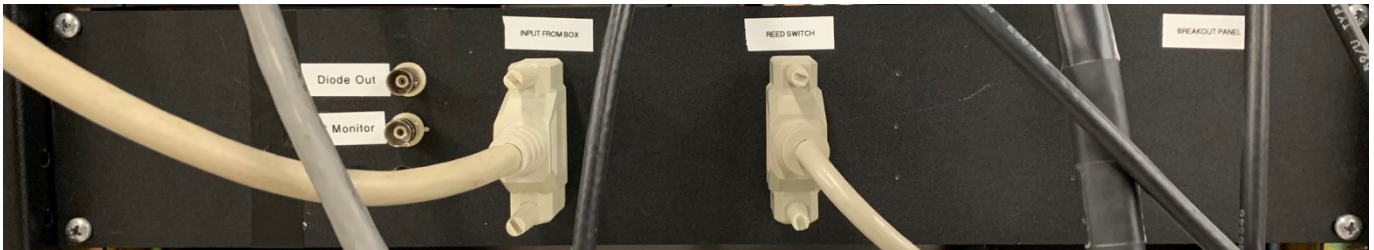

Figure 3.1: Breakout Panel

The breakout panel is shown in Figure 3.1. Its purpose is to relocate connections from the back of the Yale card to a convenient place on the front of the NMR rack. It also acts as an intermediary between the computer and the box. It was originally incorporated into the system for convenience, due to the smaller size of our box.

Input pin #	Connection pin #	Connection Purpose	Connection Type
1	M	Diode	BNC
14	G		
2	NC	N/A	N/A
15	M	DC Monitor	BNC
3	G		
16	NC	N/A	N/A
4	?	Select	25-pin D-Sub REED SWITCH
17	?		
5	?		
18	?	Convert	
6	?		
19	?		
7	24	? Gain	
20	23	? Gain	
8	NC	N/A	
21			
9			
22			
10			
23			
11			
24			
12			
25			
13			

Table 3.1: Breakout Panel connections

4 DIO (Digital In/Out) Box

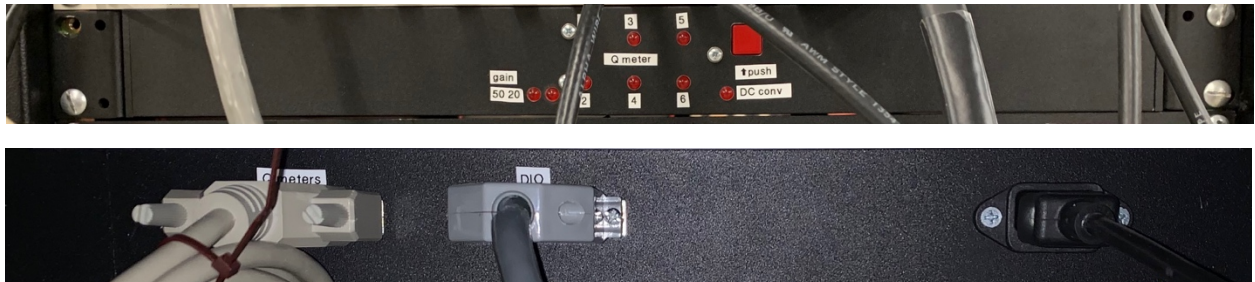

Figure 4.1: DIO box (upper panel: front view, lower panel: back view)

The DIO box, shown in Figure 4.1, acts as an intermediary between the computer and the box. It controls the Select feature, which facilitates switching between Q-meter channels from the computer. These channels are indicated on the DIO box by the six numbered lights. The DIO box also allows the user to select the desired Yale card gain from the computer. The main function of the DIO box is to DC convert the system. The DC convert signal can be sent from the computer, or activated by the button on the DIO box. The DIO box's inside is shown in Figure 4.2.

The board is 4.8" x 1.5" in size and mounts directly to the front panel of a 1U rack mount enclosure. A 2.5 mm barrel jack must connect to a 5 V power supply (see Figure 4.3) with the protection of 1A (250V) fuse (see Figure 6.2). TTL inputs come in through a 10-pin ribbon header, and a 20-pin header contains all Q meter and Yale card outputs. The circuit does not use optical isolation and must share a ground reference with both the input and output signals. The input header is divided into a DB-25 female connector with the pin assignment in Table 6.1. The input connector can interface with any 5 V TTL signal source, such as an NI DIO card or PXI module. We break out the output header to a DB-25 male connector with the pin assignment in Table 6.6.

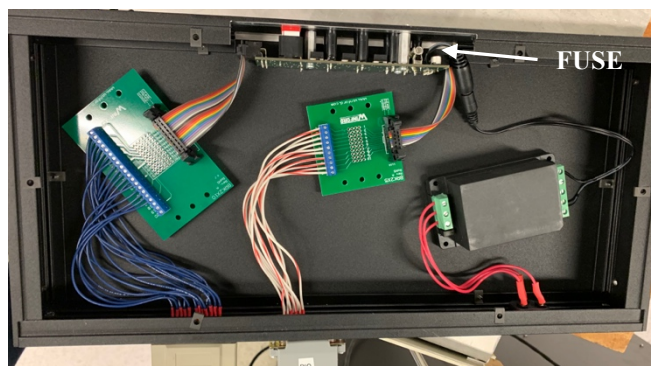

Figure 6.2: DIO box inside views

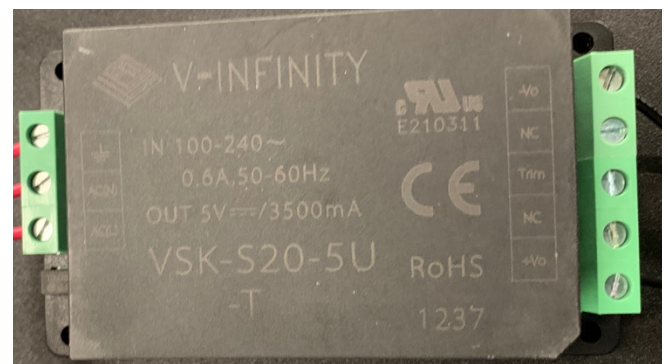

Figure 6.3: DIO box 5V power supply

ribbon	DB-25F	input
1	1	Q meter 1 enable
2	2	Q meter 2 enable
3	3	Q meter 3 enable
4	4	Q meter 4 enable
5	5	Q meter 5 enable
6	6	Q meter 6 enable
7	14	Yale gain 20
8	15	Yale gain 50
9	16	Yale DC convert
10	17	ground

Table 6.1: Input pin assignment



Figure 6.4: Connections in Table 6.1

ribbon	DB-25M pin	output
1	21	ground
2	1	Q meter 1 +
3	14	Q meter 1 -
4	2	Q meter 2 +
5	15	Q meter 2 -
6	3	Q meter 3 +
7	16	Q meter 3 -
8	4	Q meter 4 +
9	17	Q meter 4 -
10	5	Q meter 5 +
11	18	Q meter 5 -
12	6	Q meter 6 +
13	19	Q meter 6 -
14	23	Yale gain 20
15	24	Yale gain 50
16	21	Yale DC convert
17	25	ground
18	N/C	N/C
19	N/C	N/C
20	N/C	N/C

Table 6.2: Output ribbon header pin assignment

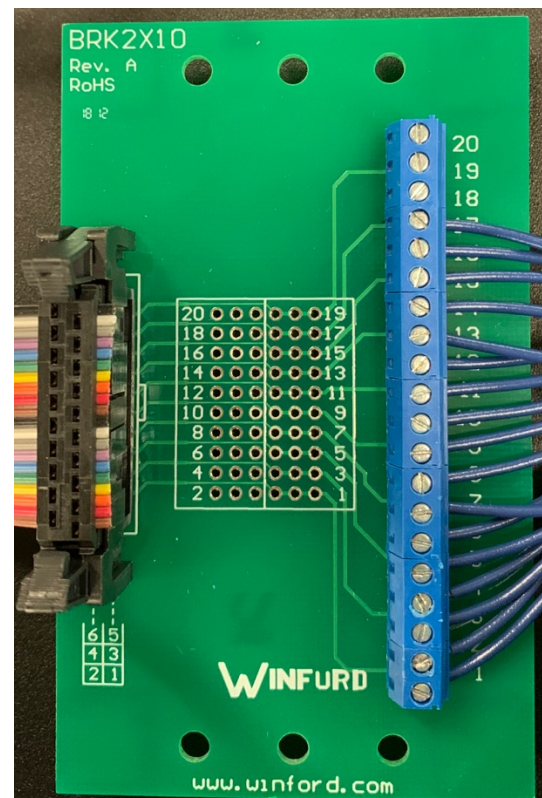

Figure 6.5: Connections in Table 6.2

The primary function of the DIO module is to select an active Q meter. Figure 4.2 shows the schematic for this circuit. Two outputs (QSHUNT+ and QSHUNT-) go to each of the six potential Q meters – one line carries the RF signal while the other carries a ground reference. We use reed relays to short these lines, shunting the RF signal to ground, when the Q meter is disabled. The relays are normally closed, meaning all Q meters are disabled by default. To enable a Q meter, a TTL signal on the corresponding input (QSELECT) opens the relay, removing the short and allowing the RF signal to enter the resonator. An LED on the front panel indicates when a Q meter is enabled.

The DIO box must also provide several TTL signals to the Yale cards. Figure 4.7 details this part of the circuit. Two inputs (GAIN20 and GAIN50) control these gain settings on the Yale cards (YALE20 and YALE50). Note that, to achieve a gain of 50, both gain 20 and gain 50 must be enabled, since these signals control series-connected amplifier stages. This DIO module buffers the signals to the Yale card, meaning the TTL input does not necessarily need to source any current.

Another important signal to the Yale card is DC convert. A 10 ms TTL pulse by the pushbutton resets the amount of DC subtraction on the Yale card. Also, either a signal on the DCCONV input or a button press will assert the YALEDC output.

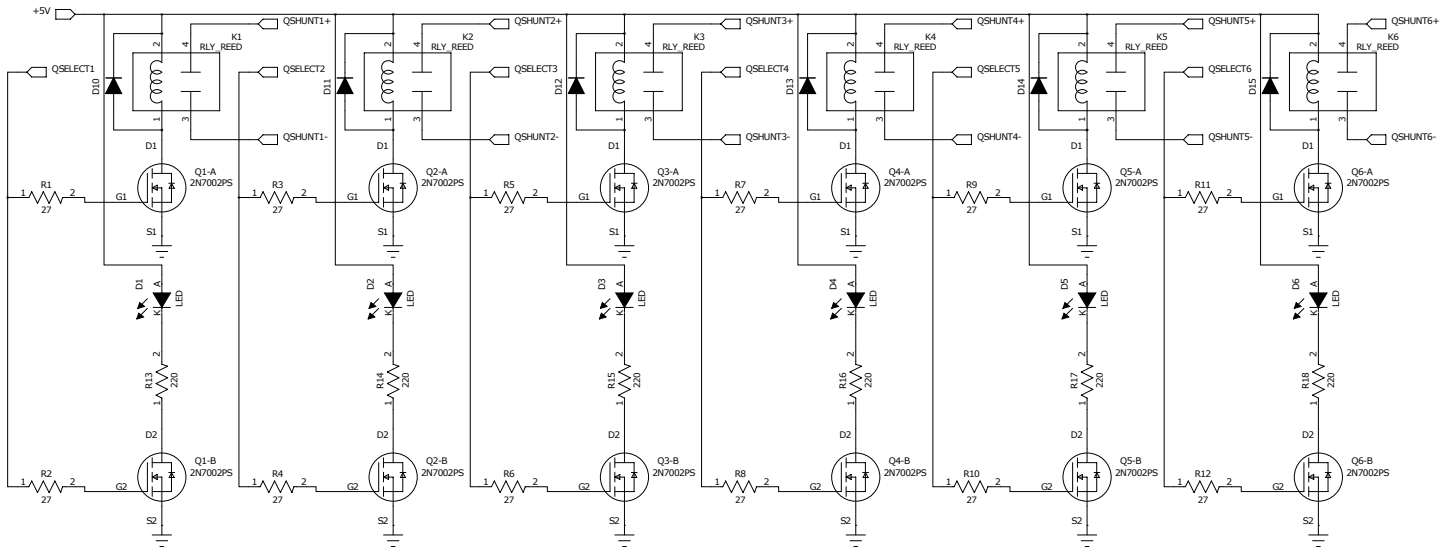

Figure 4.6: Schematic of DIO module's communication with Q-meter

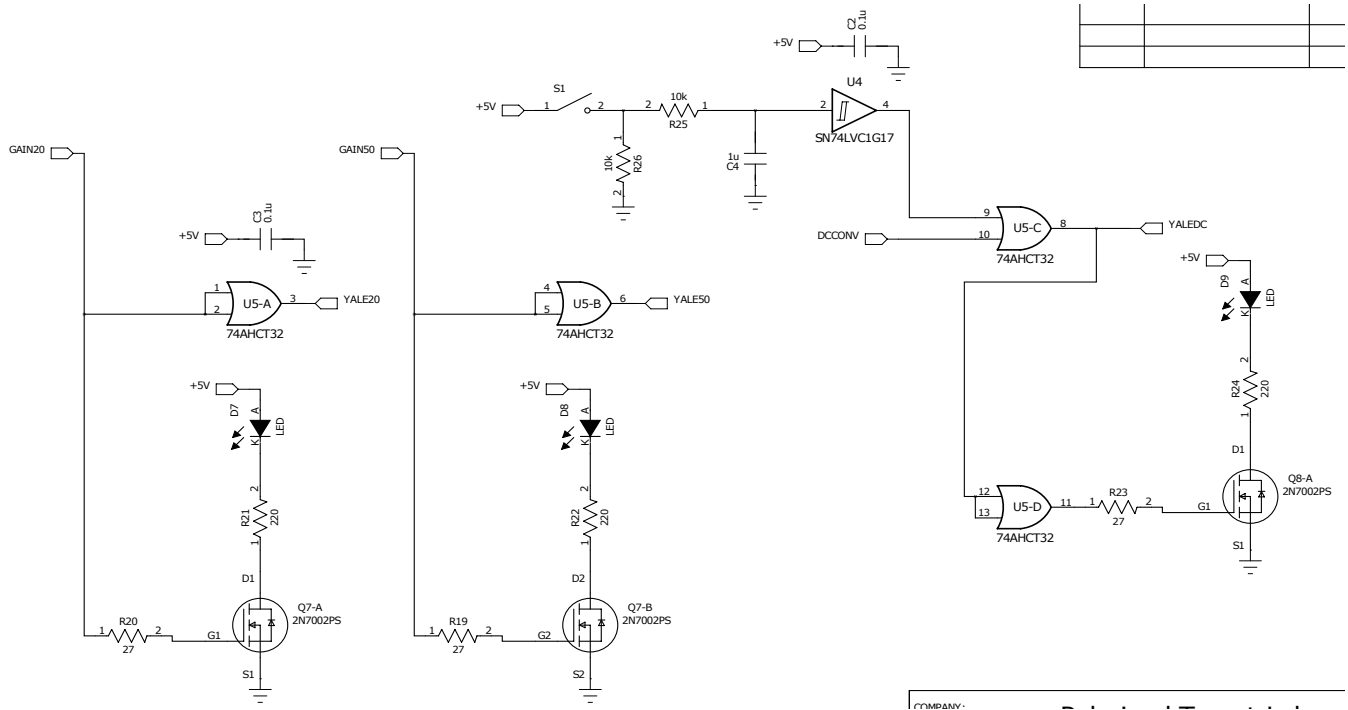

Figure 4.7: Schematic of DIO module's communication with Yale-Card

5 The Box (Containing Q-meter & Yale Card)

The “box”, sometimes referred to as “the housing”, is the device to which the Q-meter and Yale cards are attached. The box itself consists of nine metal pieces held together by various types of screws. There are three vertical panels, herein referred to as the front panel, the middle panel, and the back panel. These panels are constructed of 1/8-inch-thick aluminum plates. The space between the front and middle panels is the electronics compartment, where most of the wiring is housed. The electronics compartment is enclosed on the top and bottom by the top plate and bottom plate, respectively. The sides of the box are 1/4-inch-thick aluminum plates. The floor is a 3/8-inch-thick sheet of brass. The bottom panel makes sure the box is mostly enclosed, shielding the internal wiring from any electromagnetic interference.

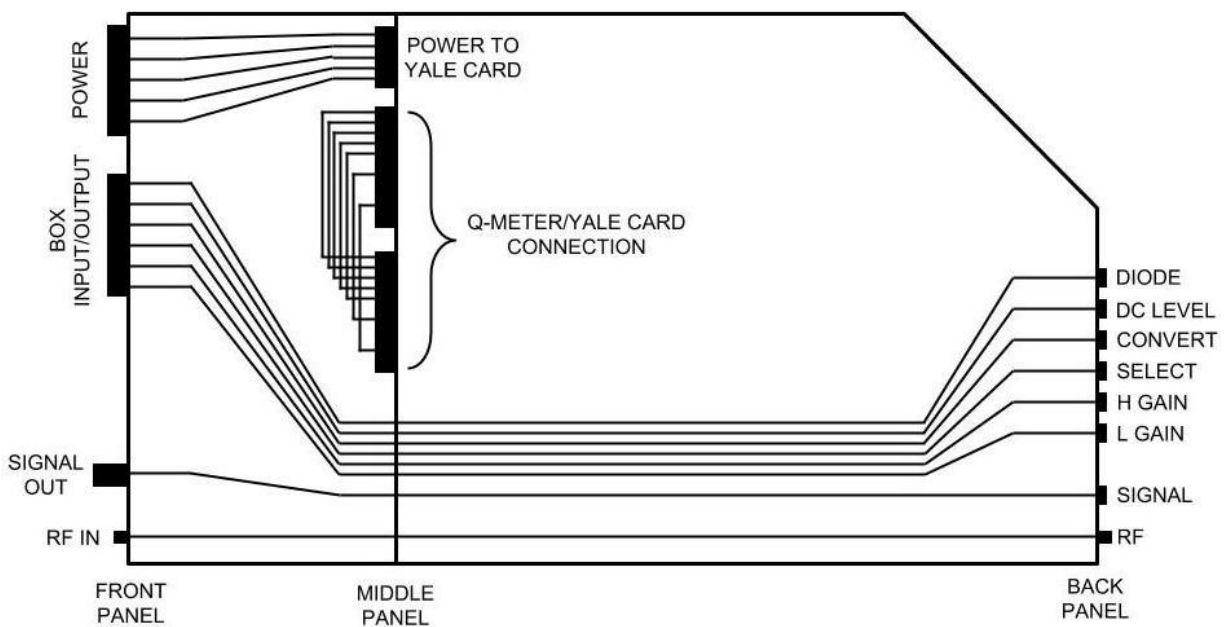

Figure 5.1 : Box wiring diagram

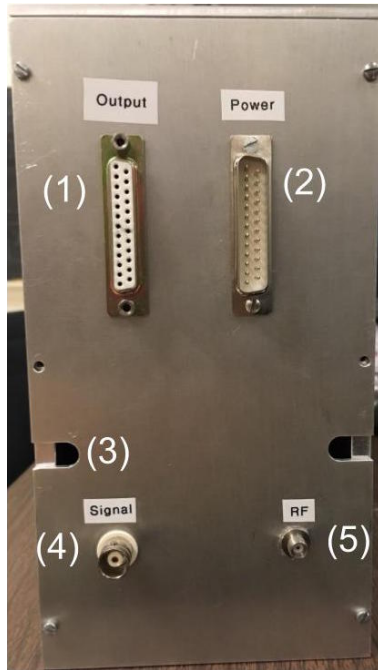

Figure 5.2: Front panel

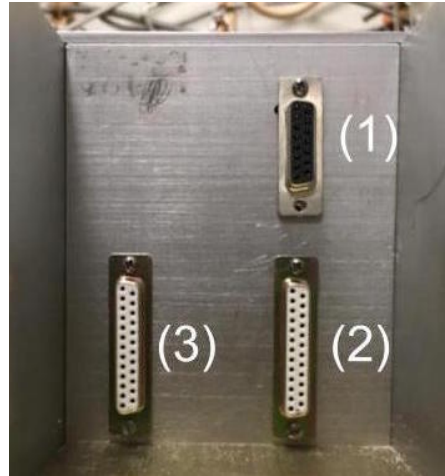

Figure 5.3: Back panel

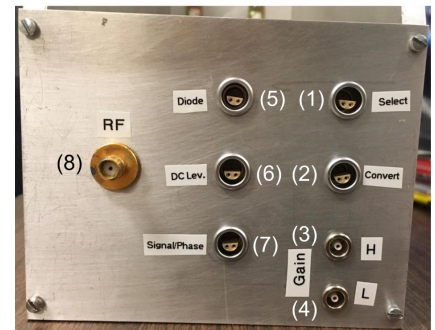

Figure 5.4: Middle panel

The Input/Output (IO) Interface of the box consolidates connectors (1) - (6) on the back panel (Figure 5.4) into one 25D connector on the front panel (number (1) of Figure 5.2). This includes (1) Select, (2) Convert, (3) High gain, (4) Low gain, (5) Diode, and (6) DC Level/DC Monitor. The box IO then transfers these signals to the breakout panel. The details of the wiring are given in Table 5.1 (see Ref. [4]). The signal/phase line is wired separately to reduce noise. The RF signal input port, number (5) in Figure 5.2, transfers the RF signal to (8) (Fig. 5.4) on the back panel. The phase signal is treated separately from the other box interfaces. The phase signal, or just the signal, is extracted from a special BNC connector on the front panel (number (4) in Figure 5.2). This is because the signal line must be shielded to reduce noise contamination. The middle panel, shown in Figure 5.3, is where the Q-meter and Yale card are connected to the box. The power input on the front panel is connected directly to (1). This 15D connector delivers power to the Yale card. The two 25D connectors (2) and (3) are wired to each other in a one-to-one manner. These connections, detailed in Tables 5.1, 5.2 and 5.3, connects the Q-meter to the Yale card.

Power Input Pin #	15D Pin #	Voltage	Power Input Pin #	15D Pin #	Voltage
1	1	+24 V	14	9	G
2	2	+15 V	15	10	G
3	3	+ 15 V	16	11	G
4	4	-15 V	17	12	G
5	5	+5 V	18	13	G
6	NC	N/A	19	NC	N/A
7			20		
8			21		
9			22		
10			23		
11			24		
12			25		
13					

Table 5.1: Box wiring connections

(2) - (3) Pin #	Connection
1	C
14	C
2	C
15	C
3	C
16	C
4	C
17	C
5	C
18	C
6	NC
19	NC
7	NC
20	C
8	C
21	NC
9	NC
22	NC
10	NC
23	C
11	C
24	NC
12	NC
25	NC
13	NC

 Table 5.2: Wiring on the middle panel
 (C: connection, NC: no connection)

Port	LEMO Pin #	Box IO Pin #
Diode	1	1
	2	14
	3	2
DC Level	1	15
	2	3
	3	16
Select	1	4
	2	17
	3	5
Convert	1	18
	2	6
	3	19
H Gain	1	7
L Gain	1	20

 Table 5.3: Wiring from the back panel to the
 on the front panel

6 Q-meter

The UVA-NMR detection system is basically a RLC circuit [1,2]. The inductive part of the circuit is a wire loop/coil of bare inductance L_0 in which the target material is placed. The polarized target material has a complex magnetic susceptibility $\chi'(\omega) = \chi(\omega) - i\chi''(\omega)$ which modifies the inductance of the coil to become

$$L = L_0(1 + 4\pi\eta\chi)$$

The constant η is known as the filling factor of the system, and is a measurement of how much target material is inside the coil. The change in inductance of the coil changes the Q-factor of the circuit. This also results in a change of impedance. By applying a frequency swept RF voltage to the circuit, the change in Q and impedance is measured by the Q-meter as a change in voltage or current. From this measurement, the (negative of the) imaginary part of the susceptibility is extracted. In a certain approximation, the polarization P of the target material is proportional to the integral,

$$P \sim - \int_0^{\infty} d\omega \operatorname{Im}[\chi(\omega)]$$

The constant of proportionality is determined by comparison with the polarization at thermal equilibrium. Please refer to the Liverpool Q-meter reference.

6.1 Q-meter circuitry

A block diagram of the NMR circuit is shown in Fig. 6.1. Everything except the $\lambda/2$ cable, the NMR coil, and the RF source are part of the Q-meter.

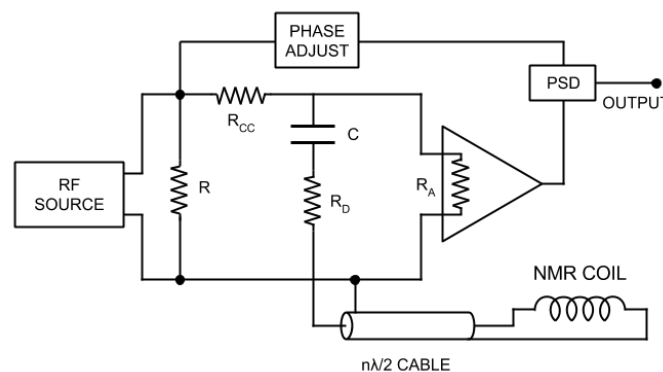

Figure 6.1: Block diagram of the NMR circuit

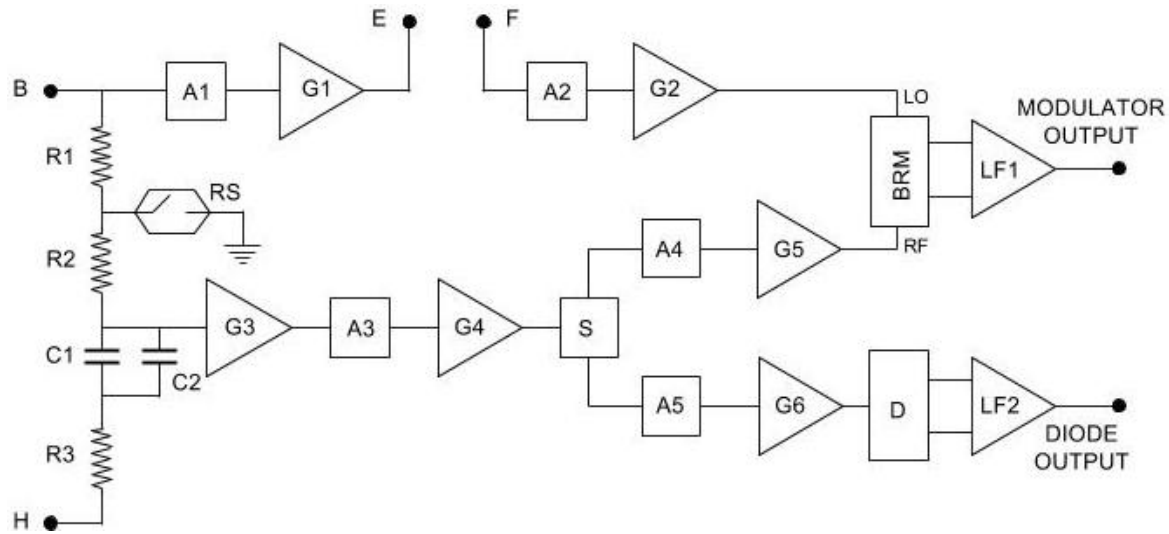

Figure 6.2: Block diagram of the Q-meter's internal circuitry. A1-5 are attenuators. G1-6 are amplifiers. R1 and R2 are the constant-current resistors, and R3 is the damping resistor. C1 and C2 are both tunable capacitors. D is a full wave diode rectifier. BRM is the balanced ring modulator. LF1 and LF2 are both differential amplifiers. S is a two-way splitter and RS is the grounding reed switch (see Refs [1,2]).

Figure 6.2 shows a more detailed block diagram of just the internal Q-meter circuitry. The RF signal generator attaches at socket B, and the $\lambda/2$ cable and coil attaches at socket H. Sockets E and F are connected by an SMA cable, the length of which is adjusted to change the phase of the reference signal.

6.2 Q-meter schematic

Q-meter's complete schematic contains five sections (labeled as PCB#1-5 in Figure 6.3) Ref [1,2]. Figure 6.4 shows a cross-sectional views of the Q-meter's inside components (front & back views). The five PCB schematics corresponding to the five sections are shown through Figures 6.5.1 – 6.5.5.

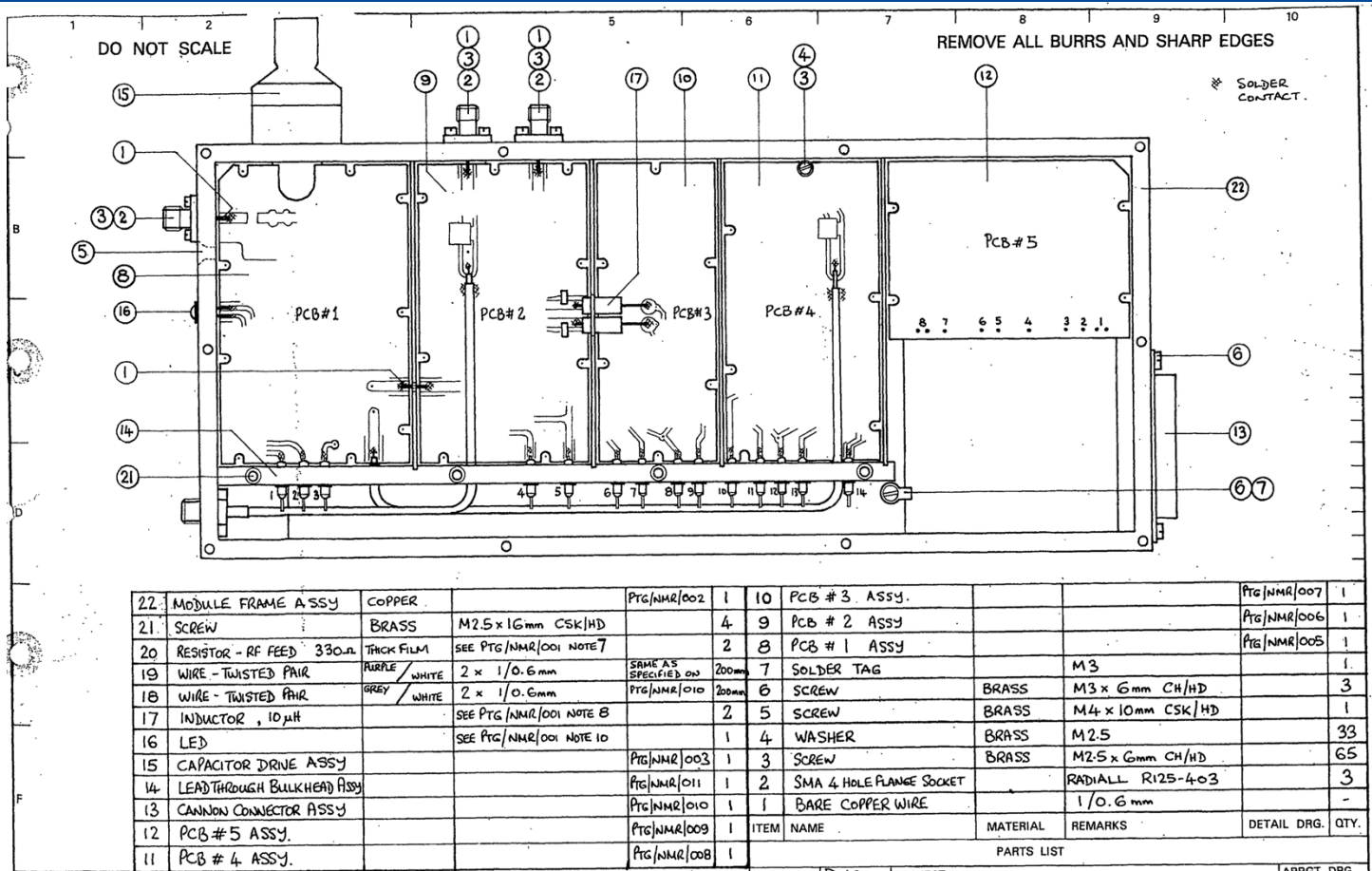

Figure 6.3: Q-meter's schematic of its internal circuitry.

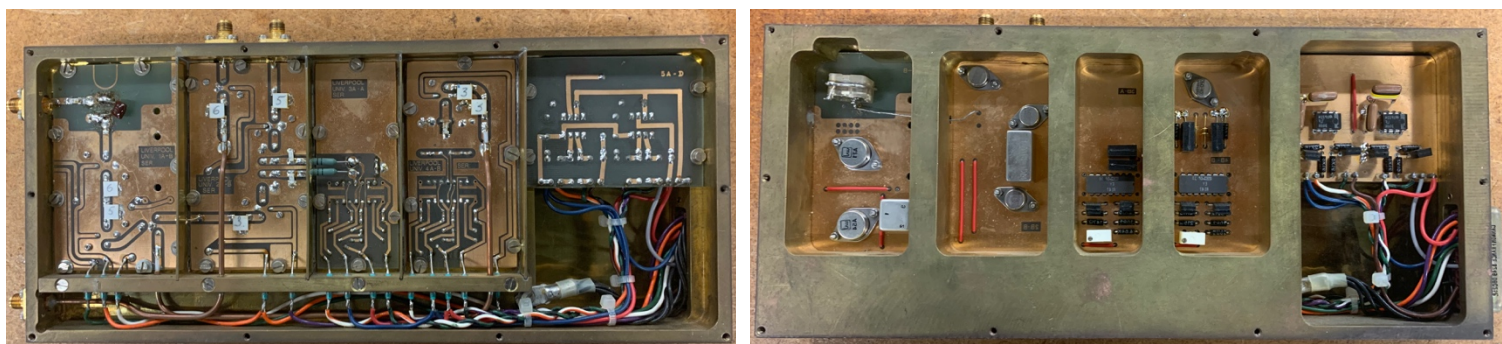

Figure 6.4: Q-meter's inside circuit images: front-side (left), back-side (right).

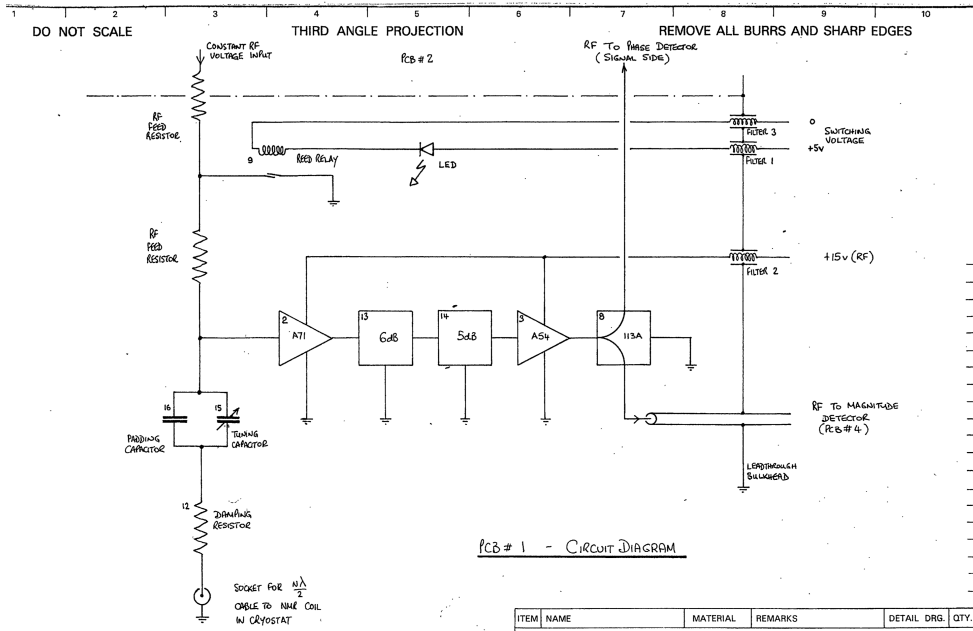

Figure 6.5.1: Q-meter's PCB #1.

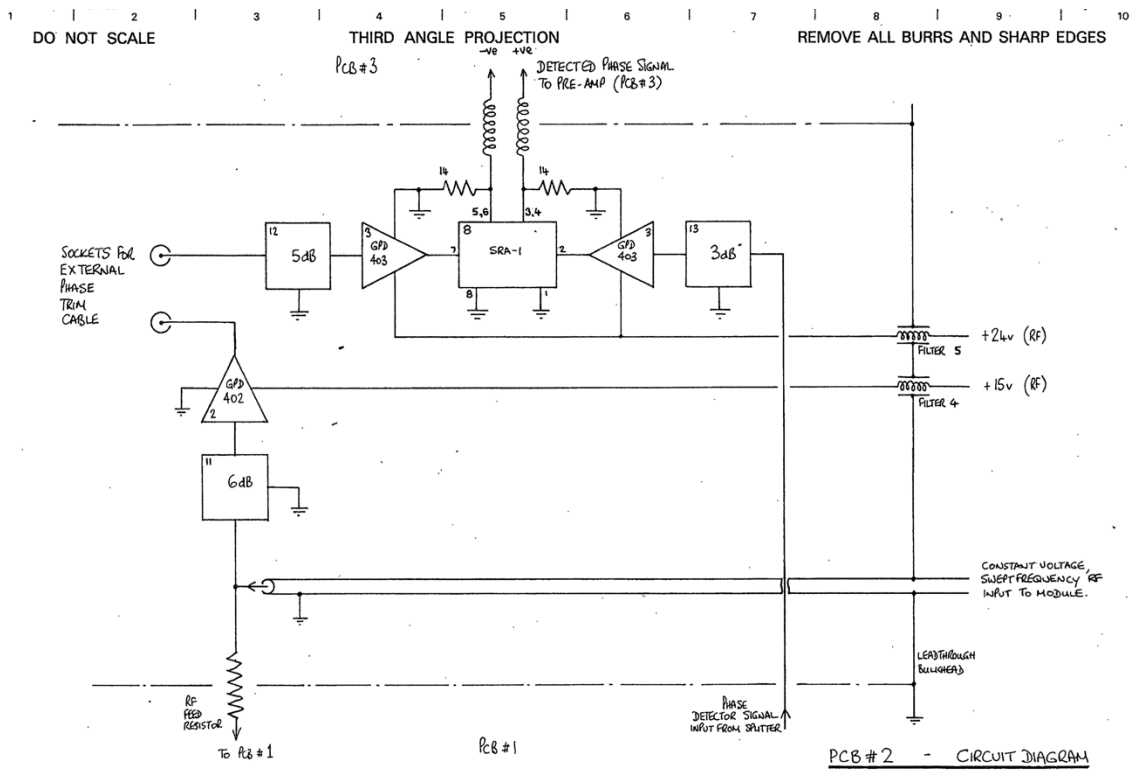

Figure 6.5.2: Q-meter's PCB #2.

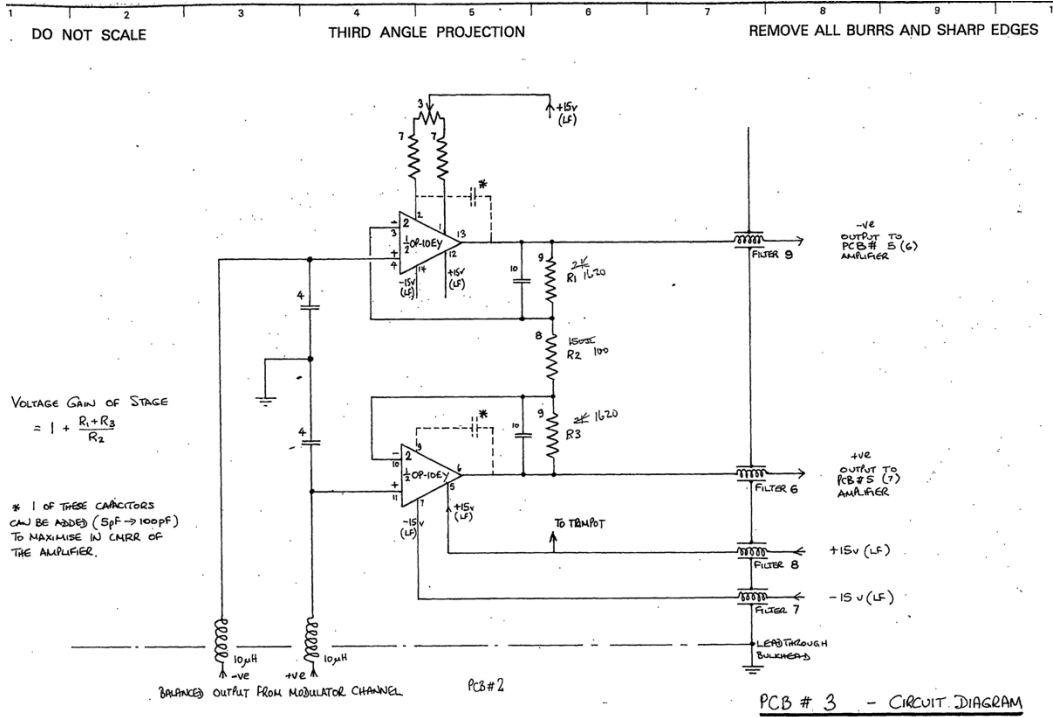

Figure 6.5.3: Q-meter's PCB #3.

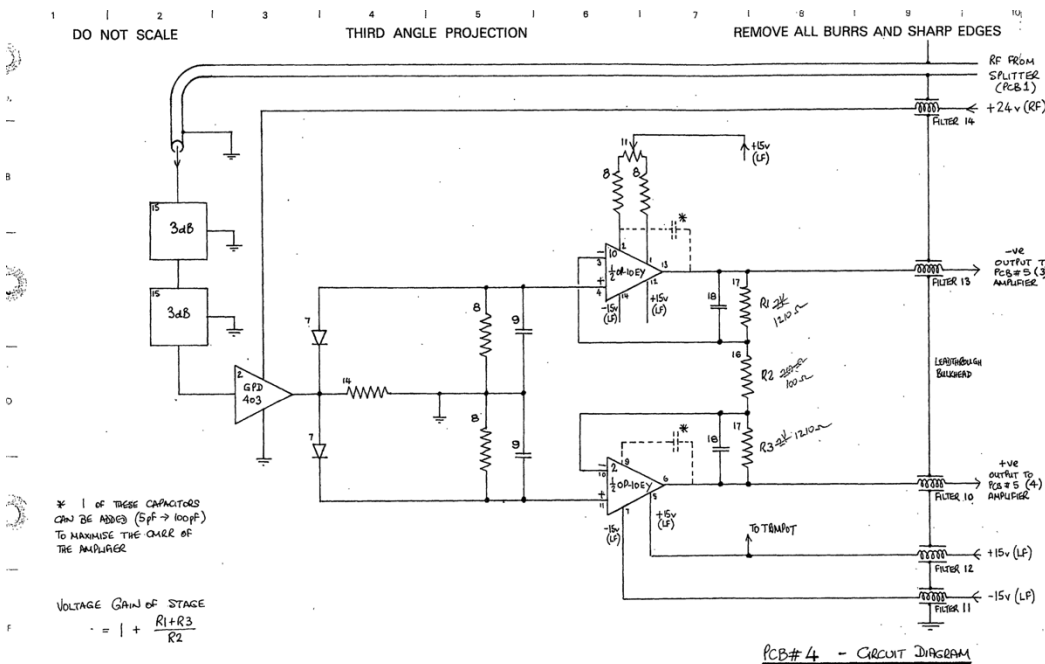

Figure 6.5.4: Q-meter's PCB #4.

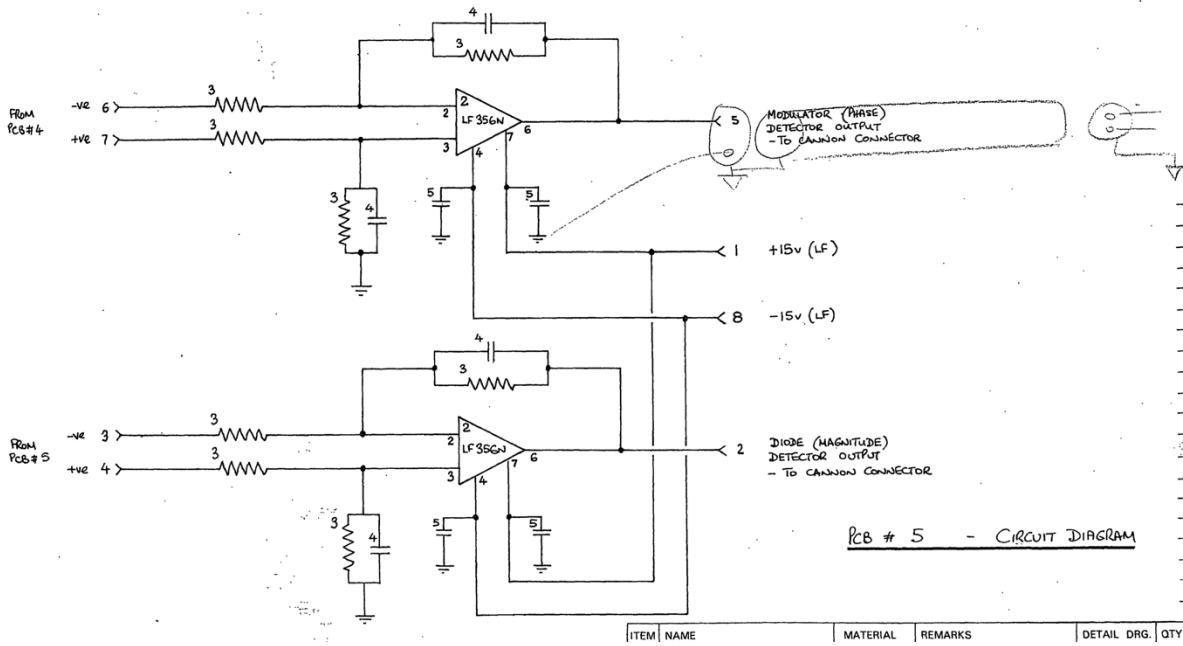

Figure 6.5.5: Q-meter's PCB #5.

6.3 Q-meter housing



Figure 6.6: Q-meter: (a) front-view (b) top-view (c) back-view

The circuitry just discussed is housed within a rectangular box, which is called a Q-meter. The front of the Q-meter housing, shown in Fig. 6.6 (a), has one 25D connector which accommodates the power supply input and detected outputs. The top of the housing, Fig. 6.6 (b), has two SMA sockets labeled (1) and (2). The knob (3) is a fine adjustment knob for the tuning capacitor. The back of the Q-meter is shown in Fig. 6.6 (c). An RF signal is delivered to the Q-meter through socket (1). The inductive coil is attached at socket (4). The small hole (3) is an access port which allows for coarse adjustment of the internal tuning capacitor (by inserting a small flat-head screwdriver into the access port to adjust the capacitor). The light (2) is an indicator light.

7 Yale-Card

The Yale card is a circuit board used for signal amplification and DC voltage compensation.

7.1 Yale-Card housing

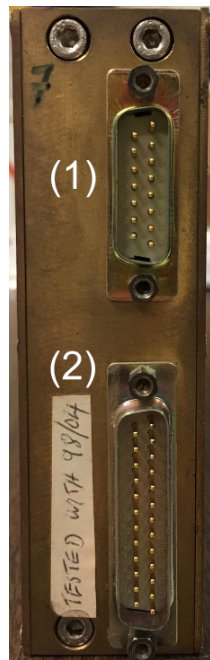

Figure 7.1 (a): Yale-Card front panel



Figure 7.1 (b): Yale-Card back panel

The front of the Yale card housing is shown in Figure 7.1 (a). Power is delivered to the internal circuit board through the 15D connector (1). The 25D connector (2) connects to the Q-meter in a one-to-one manner detailed in Table 5.2.

The back of the Yale card housing, shown in Figure 7.1 (b), holds all the interface ports. There are five 3-pin LEMO connectors for Diode, Select, Signal, DC Level/DC Monitor, and Convert. The two single-pin LEMO sockets and corresponding switches control the gain settings of the Yale card.

The Yale card has three possible gain settings (1, 20, and 50) which can be controlled manually by the switches, or electronically through the LEMO sockets. When both switches are down, there is no gain. Activating the low gain switch gives a gain of 20. Activating both switches gives a gain of 50.

7.2 Yale-Card circuitry

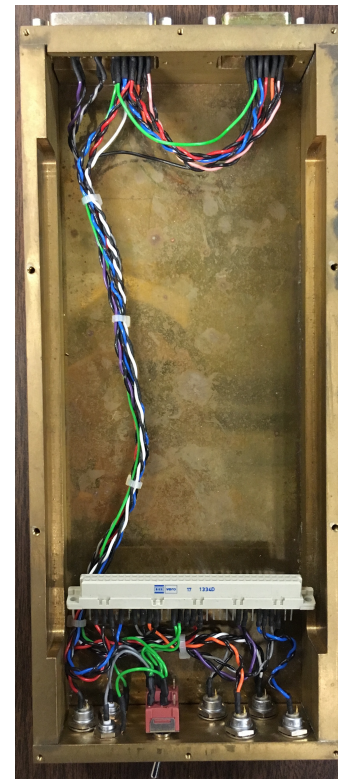
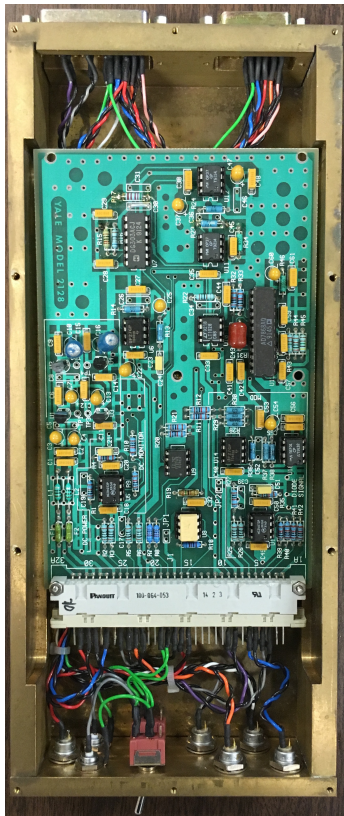

Figure 7.2 (a): Yale card housing with the circuit Figure 7.2 (b): Yale card housing

The internal wiring of the Yale card housing with (or without) the circuit board is shown in Figure 7.2 (a). The Yale card circuit board is plugged into the 32-pin DIN connector, which is wired to the 3-pin LEMO sockets and the 25D connector according to Table 7.2 (a). The 25D connector is also wired to the 15D power supply connector. The details of this connection, from the perspective of the 25D connector, are shown in Table 7.2 (b).

YC Pin #	Connection Pin #	Connection Name	Wire Color
1	NC	N/A	N/A
2			
3	25D20	?	black
4	25D8	?	gray
5	3L?	Diode	black
6	3L?		blue
7	NC	N/A	N/A
8	25D23	?	black
9	25D11	?	purple
10	NC	N/A	N/A
11			
12			
13			
14			
15	3L?	Convert	black
16	3L?		red
17	?	Reed Switch?	black
18	?	H Gain switch	green
19	?	L Gain switch	green
20	NC	N/A	N/A
21			
22	3L?	Phase/Signal	black
23	3L?		orange
24	3L?	DC Monitor/Level	black
25	3L?		gray
26	NC	N/A	N/A
27	25D4	?	blue
28	NC	N/A	N/A
29	25D17	?	black
30	25D16	?	black
31	25D3	?	red
32	NC	N/A	N/A

Table 7.2 (a): Internal wiring of Yale card Liverpool housing.
 (The notation 3LX refers to pin X of a 3-pin LEMO connector)

Pin #	Connection Pin #	Wire Color
25D1	15D1	pink
25D2	15D2	orange
25D3	15D3, YC31	red
25D4	15D4, YC27	blue
25D5	15D5, RR ??	
25D6	NC	N/A
25D7	NC	N/A
25D8	YC4	gray
25D9	NC	N/A
25D10	NC	N/A
25D11	YC9	
25D12	NC	N/A
25D13	NC	N/A
25D14	15D9	black
25D15	15D10	black
25D16	15D11, YC30	black
25D17	15D12, YC29	black
25D18	RR ??	white
25D19	NC	N/A
25D20	YC3	black
25D21	NC	N/A
25D22	NC	N/A
25D23	YC8	black
25D24	NC	N/A
25D25	NC	N/A

Table 7.2 (b): Wiring of the Yale card 25D connector.

7.3 Yale-Card schematic

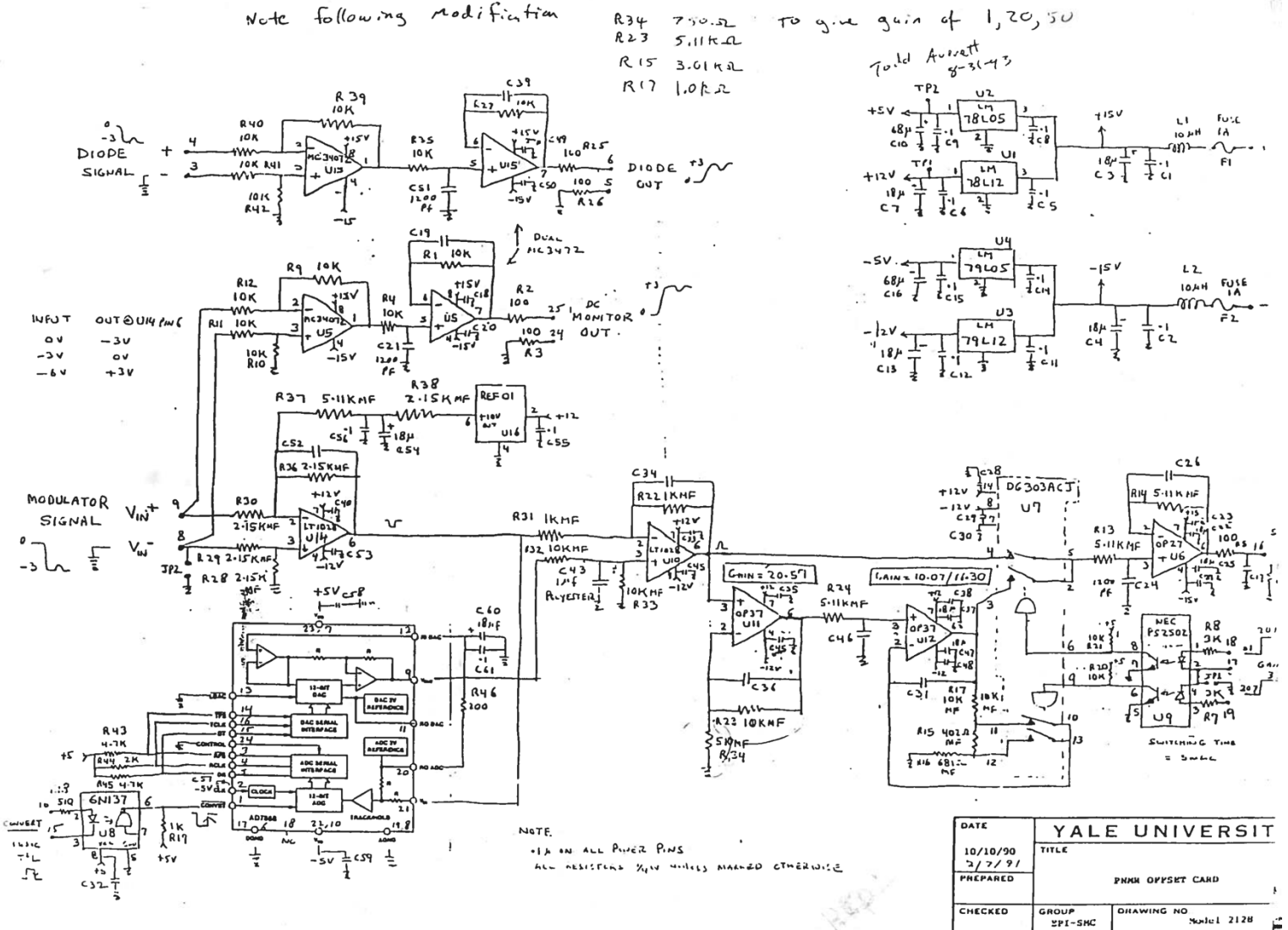

Figure 7.3: Yale-Card schematic (see Ref. [5])

8 Safety

Any component of this UVA-NMR system doesn't use high voltage or high current. RF signal generator is scanning only up to ~220 MHz. There is about nano-Watt level radiation will be exposed by the crystal that is used to tune the UVA-NMR system, and it is considerably small.

References

- [1] Liverpool Q-meter guide
- [2] Q-meter blue print (Q-meter schematics)
- [3] Q-meter power supply schematic diagram
- [4] DIO box schematics
- [5] Yale-Card schematics
- [6] Q-meter power cable data sheet (22AWG/3c (UL) TYPE PLTC or ITC or CMG 105°C (DC 105))

